

Contents

General	154
C-bracket	161
HSU trunnion type, forged, for aluminium based OPGW conductors	161
HSU with reinforcing rods, trunnion type, forged, for aluminium based OPGW conductors	163
HSU with aluminium belt, casted, for aluminium based OPGW conductors	164
Earthwire bracket with parallel groove clamp, double, for aluminium based conductors	166
Earthwire bracket with parallel groove clamp, triple, for aluminium based conductors	166
Earthwire bracket with parallel groove clamp, quad, for aluminium based conductors	167
Shunt copper, insulated	167
Shunt copper, with connection screw for clamps	168
Shunt aluminium	168
Heliformed dead end with thimble and reinforcing rods, for aluminium based conductors	169
Stockbridge damper with casted clamp, for aluminium based conductors	170
Stockbridge damper with forged clamp, for aluminium based conductors	170
Down lead clamp	171
Heliformed spiral vibration damper, for all materials	172

General

Earthwires provide earth protection for overhead power lines, protecting from lightning strikes. The grounded system releases high energy safely, providing minimum disruption to the power delivery system.



400kV
corner mast with
OPGW earthwire

Earth wires should be mounted at the highest positions of support structures, providing the highest levels of protection.

OPGW (optical groundwires) provide, in addition to system protection, **high capacity data transfer** through internal optical fibres.

The glass fibres, which are protected inside concentric or

eccentric plastic, aluminium or stainless steel tubes, are sensitive to bending and compression loads. The most reliable method of mechanical connection to the OPGW uses hand applied **helical rod type fittings**.

Two other types of optical fibre data transfer cables use these types of connecting fittings. OPPC's (optical phase conductors) and ADSS (all-dielectric self-supporting) fibre optic cables. OPPC conductors are constructed similar to OPGW, however, optical fibre tubes require disconnection from power voltages at splicing joint boxes. ADSS cables are mostly installed and operated at a similar physical elevation to the phase wire, and generally installed on systems voltages $\leq 110\text{kV}$.

The following examples show some typical applications. However, fittings also are available to all the other options.

Suspension of a fibre optic cable by means of a C-bracket on a suspension tower

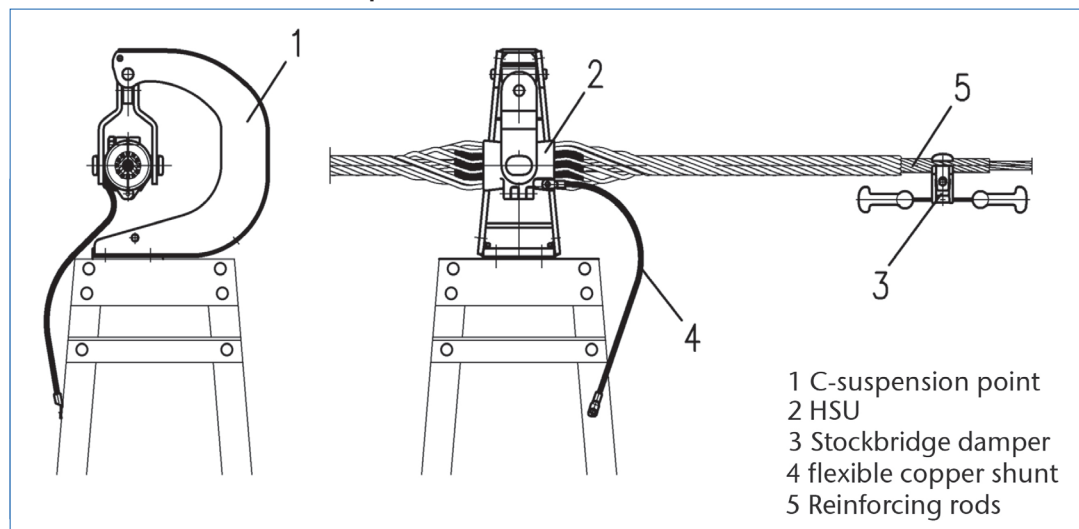

View of a
suspension point
for an OPGW
with a C-bracket

- 1 C-suspension point
- 2 HSU
- 3 Stockbridge damper
- 4 flexible copper shunt
- 5 Reinforcing rods

Tensioning a fibre optic cable with down lead clamps

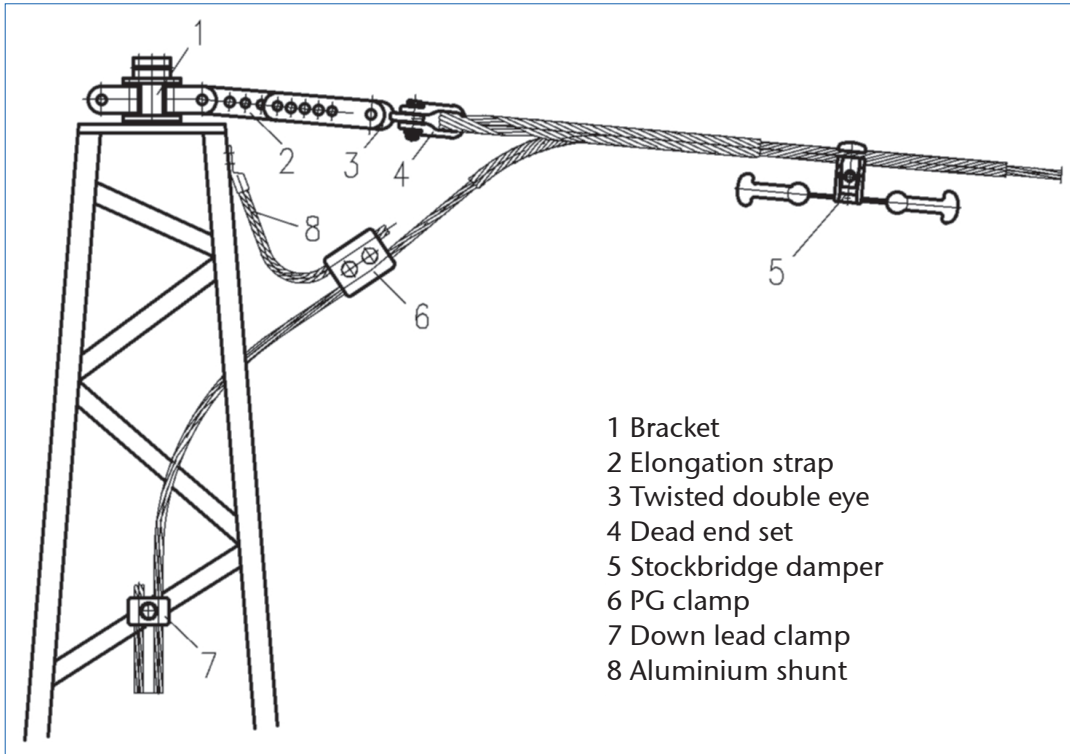

- 1 Bracket
- 2 Elongation strap
- 3 Twisted double eye
- 4 Dead end set
- 5 Stockbridge damper
- 6 PG clamp
- 7 Down lead clamp
- 8 Aluminium shunt

View of a tensioning point for an OPGW with down lead clamps

Suspension of an ADSS cable by means of a roller suspension clamp

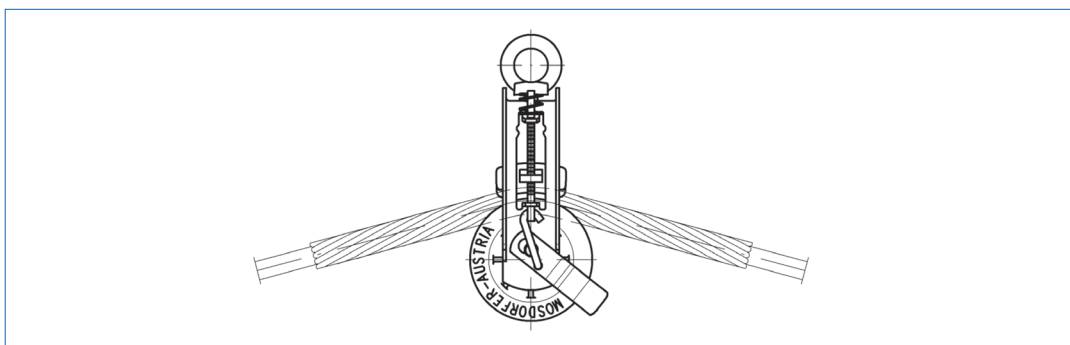

Suspension of an ADSS cable by means of a roller suspension clamp

Tensioning of an ADSS cable

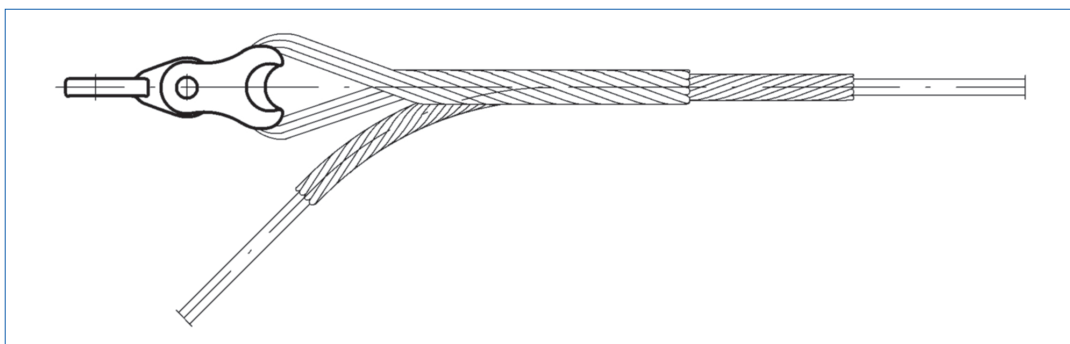

Tensioning of an ADSS cable with a helical dead end

156

High load withstand long span suspensions and tensioning systems for ground wires e.g. fjord or river crossings:

Suspension of an OPGW conductor with a double HSU unit (left) and tensioning of a big OPGW conductor with a double heliformed dead end (right)

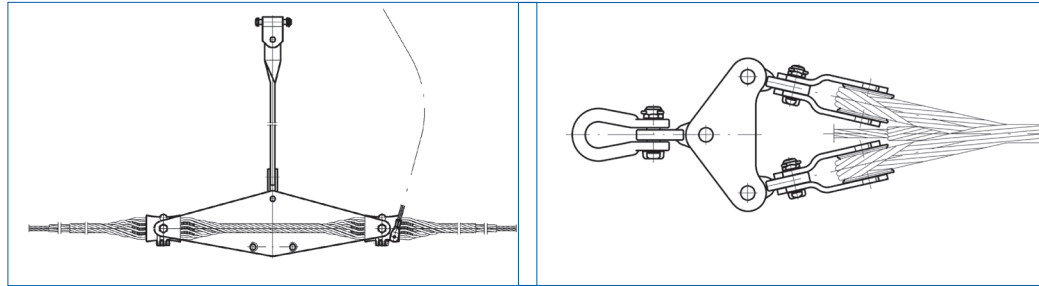

Vibration protection

Optical fibre cables are sensitive to pressure and vibrations, requiring special design consideration in all applications.

To protect the cables from radial clamping forces, any compressive loads applied directly to the cable must be controlled.

Application of a protective layer of hand applied helically formed rods protects the cable and internal fibres, reducing the effect of compressive loads applied by clamps and tension fittings. Vibration damper clamps must be applied over helical rod sets at the correct installation torque.

For vibration control, Stockbridge dampers are normally used.

Example for a calculation:
Tensioning point with two dampers

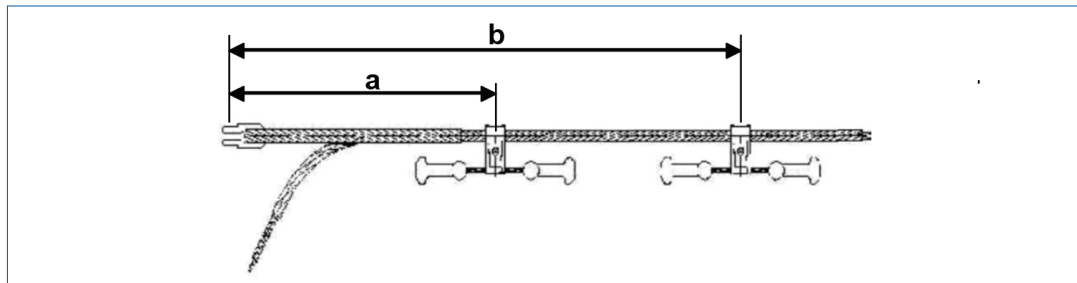

When considering the damping protection, MOSDORFER's computational programs also consider the influence of the helical fittings. At tension points, provision for two vibration dampers to be applied safely are normally required.

A more detailed description of this damper type can be found in **Part 10** of our catalogue.

Example for a calculation:
Warning sphere with a Stockbridge damper

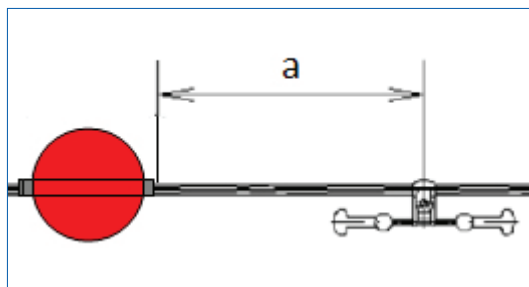

Stockbridge dampers will also be used where warning spheres are mounted on longer protective rod sets. If a second damper is necessary it will also be applied to the rods with applied lengths and damper positions determine by vibration studies.

Cone type tension clamps

Alternatively it is possible to use cone type clamps to tension the OPGW cables.

These clamps work in the same way as wedge tension clamps, but the wedges are cone shaped. Cones are available with or without jumper connections. Depending upon the construction of the conductors or OPGW it can be necessary to use reinforcing rods.

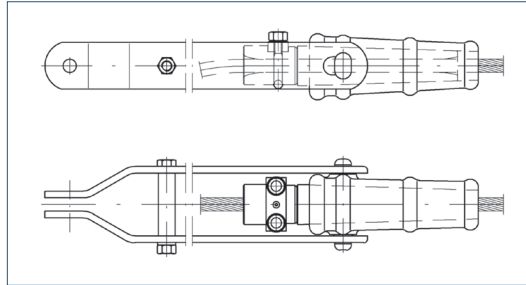

Cone type
tension clamp

Cone diameters will be calculated acc. to the conductor dimensions.

Warning spheres

Warning Spheres are installed on groundwires to warn low flying aircraft of the elevated obstacles.

These are generally positioned on routes near airports and elevated spans on the uppermost earthwire cable.

The warning device consists of two hemispheres attached to the groundwire by two bolted clamps.



Warning sphere

The Spheres are 600 mm diameter; all other details available on request.

The Warning spheres can be delivered in three different Types of UV and Ozone resistant colours – red, orange and white or alternating - white/orange or white/red.

Spiral dampers

For smaller diameter and ADSS cables, spiral dampers are available. These dampers are one piece weather and abrasion resistant plastic.

The helical design enables easy and reliable mounting, with the smaller spiral attached to the cable.

Damping is achieved by differential movement of the helical rod versus the cable.

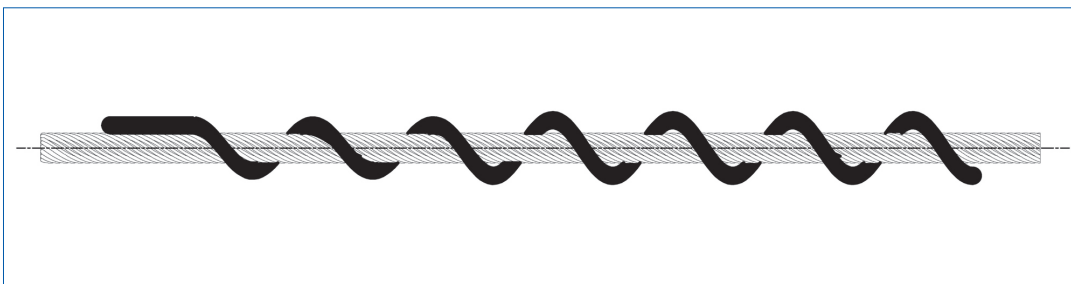

Spiral damper:
weather and
abrasion resistant
plastic

158

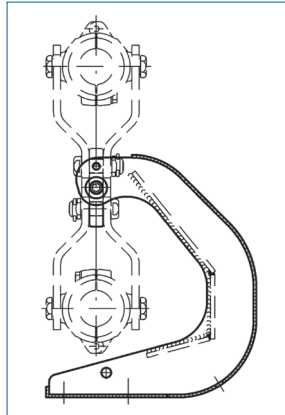

C-bracket with a big degree of freedom

C-brackets

C-bracket supports offered in the table provide special type options, e.g. higher degrees of movement at the hinge connection, providing movement $>200^\circ$ for the suspension clamp.

Full vertical orientation of the clamp is also possible. C-bracket mounting base plates can also be adapted to suit specific tower mounting plates.

A type with a central plate is also available.

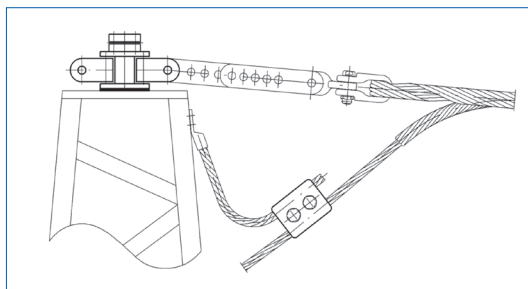

Groundwire bracket with a parallel groove clamp

For making it easier to measure earth resistance, there is an insulating set.

This set can also be used for suspension and tension brackets.

Then these brackets will be earthed on the tower by means of flexible connections.

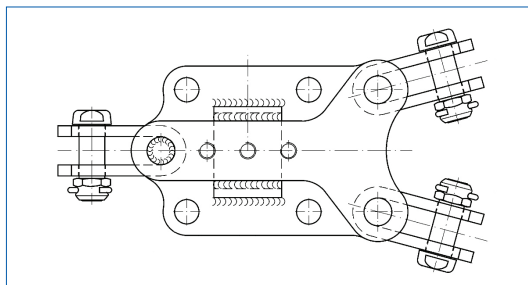

Groundwire bracket

Earthwire suspension and tension brackets

There are many options available, both with and without earth clamps. If only one conductor is to be clamped, the opposite groove can be fitted with a filler piece.

Bracket attachments are not supplied with screws as standard. These can be provided separately once attachment details are confirmed. Different clamp bore sizes and spacing

are also available, complete with corresponding screw lengths and sizes.

Tension brackets can also be adapted to suit specific applications.

Suspension brackets for clamps with forged trunnion's are available as a split clamp bolted type fitting.

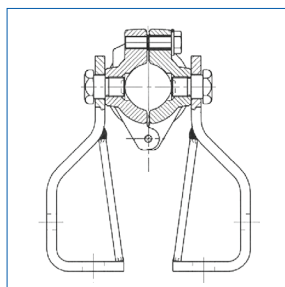

Parallel groove clamp with a divided bracket

Suspension and tension clamps, including parallel groove clamps that can also be used for conductors are described in **Parts 4, 5 and 6**.

Other accessories, shackles, links or turnbuckles can be found in **Part 3**.

For Vibration control devices, please refer to **Part 10**.

Eye-clevis connections are designed acc. to *IEC 61471* and *DIN 48074* - Eyes and clevises; connecting dimensions, Bolts acc. to *DIN 48073* - Connecting bolts for overhead power lines.

Bolt security split pins are manufactured in stainless steel.

Material

- All materials used are fully compatible with the conductor application. For example, clamps attached to Aluminium based conductors are manufactured from high strength corrosion resistant aluminium alloys.
- Unless otherwise specified, all ferrous components are hot dipped galvanized acc. to EN 61284 or ISO EN 1461; Overhead lines-requirements and tests for fittings. Where stainless steel fasteners are used, ISO EN 3506; Mechanical properties of corrosion resistant stainless steel fasteners - Part 1: Bolts, screws and studs are specified.
- **For special cases where big dynamic loads may occur at low temperatures, fittings made of low-temperature (cryogenic) steels are available.**
- **For lines constructed in higher corrosive atmospheres and environments, the minimum zinc thickness of fittings can be increased from 85 μ to 110 μ or 130 μ Microns.**
- All fitting assemblies supplied have **identification marking** according to EN 61284; this includes manufactures mark and date code, specified minimum mechanical failure load, and 1 second short circuit current withstand rating.

Helical wire fittings

Helical wire fittings are made of formed round wire rods, with the ends shaped depending on the material and diameter. The formed diameters of the wires are smaller than the diameter of cable to be applied. This creates uniform radial pre compression of the spiral without permanent distortion of the wires or sub-sets. This applies the initial low stress grip of the cable, which increases as a resultant of higher tension forces that convert to high frictional grip. Uniform radial loads and grip increase over a longer application and contact length that provide low relative and uniform radial stress.

The main applications for helical wire fittings are reinforcement of suspension points and tensioning of fibre optic cables.

For reinforcement of the Suspension point HSU with or without reinforcing rods will be used.

Helical dead ends have multiple formed wires bonded together with a formed loop for strain thimble attachment. The inside of the helix of all helical tension fittings have a high friction textured finish to improve grip. The materials used are fully compatible with the cable being applied.

Warning spheres and Stockbridge dampers will also be mounted on helical rods.

Helical rods are also used to restore and repair cable damage. The types of fittings required is dependent on the cable and type of damage e.g. line guards, armour rods, repair sleeves, splices etc.

Identification and labelling of products are in accordance with *IEC 61284* (Rules of behaviour with respect to possible hazards when dealing with electric equipment and equipment employing similar techniques) will either be printed on individual rod sets or stated on a label connected to the set.

The lay direction of the helical rods is normally same as that of the outermost layer of the conductor, typically right hand lay.

The material used is the same as that of the conductor.

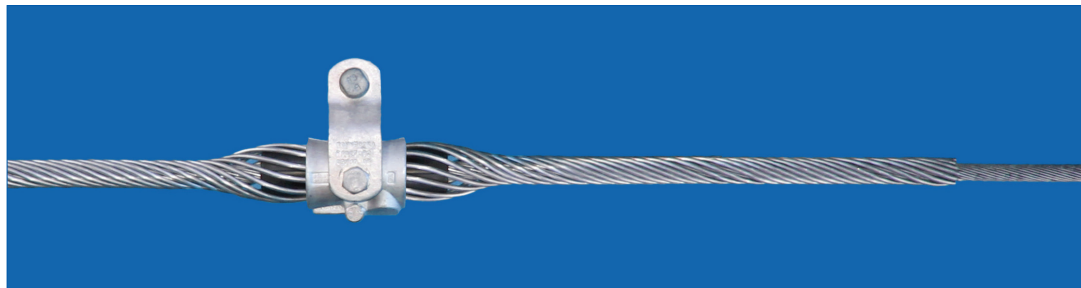

Example of a HSU

C-bracket

material: steel, welded, hot dip galvanized

L.-Nr.	dimensions in mm					max. vertical load kN	max. horizontal load kN	kg
	A	B	C	D	E			
4654.01S	265	20	90	18	20	30	15	13,65
4654.03	310	20	90	18	20	30	15	18,60
4654.04	310	20	90	18	20	40	70	24,00
4654.01	265	20	90	18	20	45	20	12,80

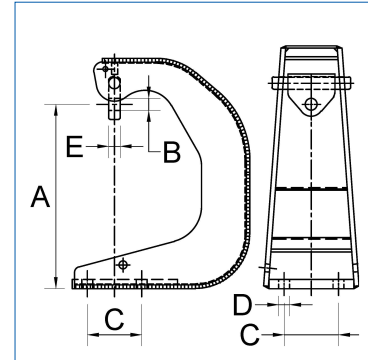

C-brackets for conductor uplift and with other hole centres or equipped with insulating accessories are available upon request.

Fastening screws can be delivered upon request.

Other types are available upon request.



HSU trunnion type, forged for aluminium based OPGW conductors

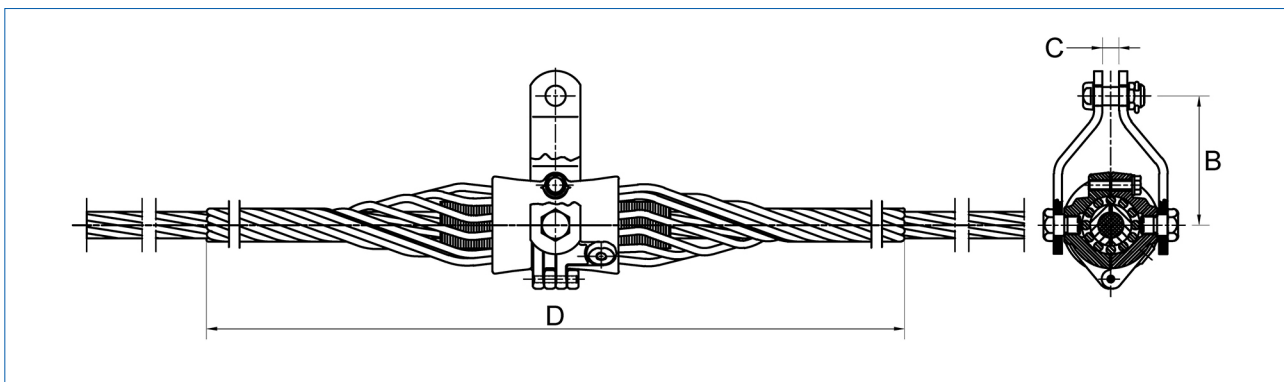

material: aluminium, forged; aluminium-rods; steel, hot dip galvanized; neoprene

L.-Nr.	dimensions in mm				bolt	kN	kA 1s	kg
	cond.Ø	B	C	D				
4361.08/1	12,70 - 13,02	90	20	1800	19	80	32	2,20
4361.09/1	13,03 - 13,48	90	20	1800	19	80	32	2,30
4361.10/1	13,49 - 13,78	90	20	1800	19	80	32	2,30
4361.11/1	13,79 - 14,11	90	20	1800	19	80	32	2,40
4361.12/1	14,12 - 14,57	90	20	1800	19	80	32	2,40
4361.13/1	14,58 - 15,10	90	20	1800	19	80	32	2,40
4361.14/1	15,11 - 15,41	90	20	1800	19	80	32	2,40
4361.15/1	15,42 - 15,74	90	20	1800	19	80	32	2,40
4361.16/1	15,75 - 16,40	90	20	2000	19	80	32	2,20
4361.17/1	16,41 - 17,11	90	20	2000	19	80	32	3,10

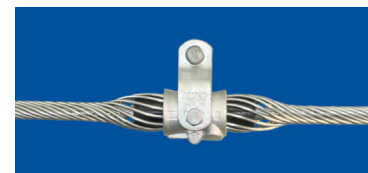

material: aluminium, forged; aluminium-rods; steel, hot dip galvanized; neoprene

L.-Nr.	dimensions in mm				bolt	kN	kA 1s	kg
	cond.Ø	B	C	D				
4361.18/1	17,12 - 17,45	90	20	2000	19	80	32	3,40
4361.19/1	17,55 - 18,05	90	20	2000	19	80	32	3,20
4361.20/1	18,06 - 18,58	90	20	2000	19	80	32	3,00
4361.21/1	18,59 - 19,07	90	20	2000	19	80	32	3,30
4361.22/1	19,08 - 19,52	120	20	2000	19	110	35	5,20
4361.23/1	19,53 - 20,21	120	20	2000	19	110	35	4,50
4361.24/1	20,22 - 20,95	120	20	2000	19	110	35	4,50
4361.25/1	20,96 - 21,48	120	20	2000	19	110	35	4,60
4361.26/1	21,49 - 22,11	120	20	2000	19	110	35	4,60
4361.27/1	22,12 - 22,70	120	20	2200	19	110	35	5,00
4361.28/1	22,71 - 23,05	120	20	2200	19	110	35	5,00
4361.29/1	23,06 - 23,38	140	20	2200	19	120	35	5,40
4361.30/1	23,39 - 23,82	140	20	2200	19	120	35	5,40
4361.31/1	23,83 - 24,45	140	20	2200	19	120	35	5,40
4361.32/1	24,46 - 25,06	140	20	2200	19	120	35	5,60

These articles are based on right-hand-layed conductors. Articles for left-hand-layed conductors are available upon request.

The screw type bolts of these clamps have been mounted in line with the conductor axes. This will help to improve mobility and reduce alternating bending strains caused by vibrations. In order to minimize abrasion between the eyes and the screw type bolts, these parts are made of steel. HSU's (heliformed suspension units) can be used for a conductor angle of up to 30°. Conductor angles of up to 60° will be possible if two bodies are connected by a suitable yoke plate via a combined heliformed rod.

These HSU's can also be used for **ADSS Cables (All-Dielectric Self-Supporting Cables)**. In order to select the correct product, detailed data about the conductor configuration will be necessary. Other dimensions are available upon request.

HSU with reinforcing rods, trunnion type, forged for aluminium based OPGW conductors

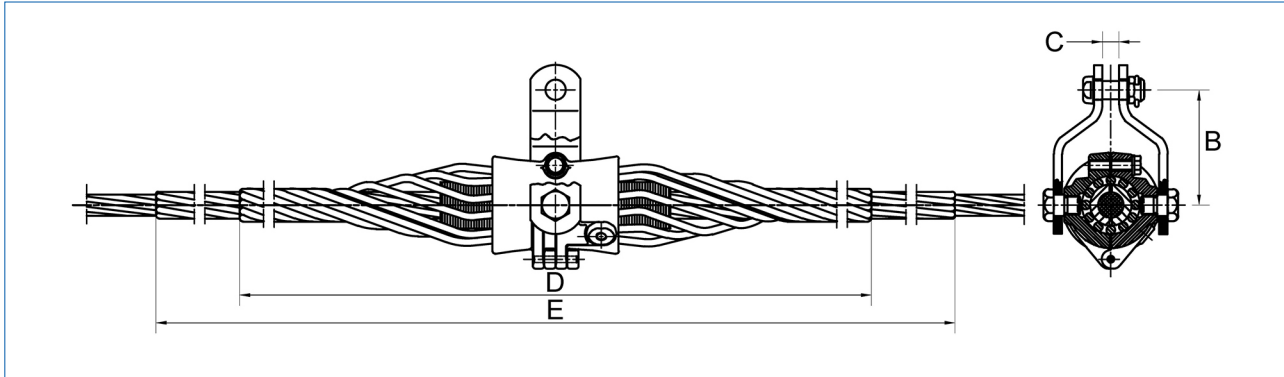

material: aluminium, forged; aluminium-rods; steel, hot dip galvanized; neoprene

L.-Nr.	dimensions in mm					bolt	kN	kA 1s	kg
	cond.Ø	B	C	D	E				
4362.00/05	9,32 - 9,90	90	20	1270	1570	19	80	32	2,60
4362.00/09	9,91 - 10,26	90	20	1270	1670	19	80	32	2,70
4362.00/08	10,27 - 10,51	90	20	1370	1770	19	80	32	2,70
4362.00/07	10,52 - 10,97	90	20	1370	1770	19	80	32	2,80
4362.00/06	10,98 - 11,09	90	20	1370	1770	19	80	32	2,90
4362.00/1	11,10 - 11,40	90	20	1370	1770	19	80	32	2,90
4362.01/1	11,41 - 11,78	90	20	1370	1770	19	80	32	3,00
4362.02/2	11,79 - 11,91	90	20	1370	1770	19	80	32	3,00
4362.03/1	11,92 - 12,46	90	20	1400	1770	19	80	32	3,10
4362.05/1	12,47 - 12,93	90	20	1420	1820	19	80	32	3,20
4362.04/1	12,94 - 13,25	120	20	1520	1920	19	110	35	4,60
4362.06/1	13,26 - 13,38	120	20	1520	1920	19	110	35	4,60
4362.07/1	13,39 - 14,01	120	20	1520	1920	19	110	35	6,46
4362.08/1	14,02 - 14,81	120	20	1550	1950	19	110	35	4,80
4362.09/1	14,82 - 14,87	120	20	1630	1950	19	110	35	4,80
4362.10/1	14,88 - 15,28	120	20	1650	2050	19	110	35	4,90
4362.11/1	15,29 - 15,41	120	20	1650	2050	19	110	35	5,00
4362.12/1	15,42 - 15,63	120	20	1650	2080	19	110	35	5,10
4362.13/1	15,64 - 15,96	140	20	1680	2080	19	120	35	6,60
4362.16/1	15,97 - 16,02	140	20	1680	2080	19	120	35	6,02
4362.17/1	16,03 - 16,40	140	20	1680	2080	19	120	35	6,30
4362.18/1	16,41 - 16,65	140	20	1700	2080	19	120	35	6,60
4362.14/1	16,66 - 17,03	140	20	1700	2440	19	120	35	6,70
4362.19/2	17,04 - 17,26	140	20	1730	2440	19	120	35	6,90
4362.15/1	17,27 - 17,64	140	20	1730	2440	19	120	35	6,80
4362.21/1	17,65 - 17,87	140	20	1750	2440	19	120	35	6,80
4362.20/1	17,88 - 18,12	140	20	1750	2150	19	120	35	6,90
4362.22/1	18,13 - 18,55	150	20	2030	2480	19	110	35	10,80
4362.23/1	18,56 - 18,81	150	20	2080	2480	19	110	35	10,10
4362.24/1	18,82 - 19,01	150	20	2080	2480	19	110	35	10,20
4362.25/1	19,02 - 19,88	150	20	2080	2480	19	110	35	10,20
4362.26/1	19,89 - 20,13	150	20	2080	2480	19	110	35	10,20
4362.27/1	20,14 - 20,28	150	20	2080	2480	19	110	35	10,40
4362.29/1	20,29 - 20,99	150	20	2080	2480	19	110	35	10,40
4362.28/1	21,00 - 21,35	150	20	2080	2480	19	110	35	10,40

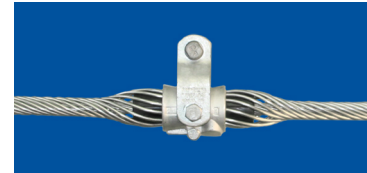

material: aluminium, forged; aluminium-rods; steel, hot dip galvanized; neoprene

L.-Nr.	dimensions in mm					bolt	kN	kA 1s	kg
	cond.Ø	B	C	D	E				
4362.30/1	21,36 - 21,45	150	20	2080	2480	19	110	35	10,60
4362.31/1	21,46 - 21,86	150	20	2080	2480	19	110	35	10,60
4362.32/1	21,87 - 22,44	150	20	2080	2480	19	110	35	10,60
4362.33/1	22,45 - 22,82	150	20	2080	2480	19	110	35	10,60
4362.34/1	22,83 - 23,51	155	20	2240	2640	19	120	40	12,80
4362.35/1	23,52 - 24,25	155	20	2240	2640	19	120	40	12,80
4362.36/1	24,26 - 25,06	155	20	2240	2640	19	120	40	12,90
4362.37/1	25,07 - 25,19	155	20	2240	2640	19	120	40	13,10

These articles are based on right-hand-layed conductors. Articles for left-hand-layed conductors are available upon request.

The screw type bolts of these clamps have been mounted in line with the conductor axes. This will help to improve mobility and reduce alternating bending strains caused by vibrations. In order to minimize abrasion between the eyes and the screw type bolts, these parts are made of steel. HSU's (heliformed suspension units) can be used for a conductor angle of up to 30°. Conductor angles of up to 60° will be possible if two bodies are connected by a suitable yoke plate via a combined heliformed rod.

HSU's with an additional reinforcing rod will preferably be used for cable types that are particularly sensitive for instance in the case of optical cables.

These HSU's can also be used for **ADSS Cables (All-Dielectric Self-Supporting Cables)**. In order to select the correct product, detailed data about the conductor configuration will be necessary. Other dimensions are available upon request.

HSU with aluminium belt, casted for aluminium based OPGW conductors

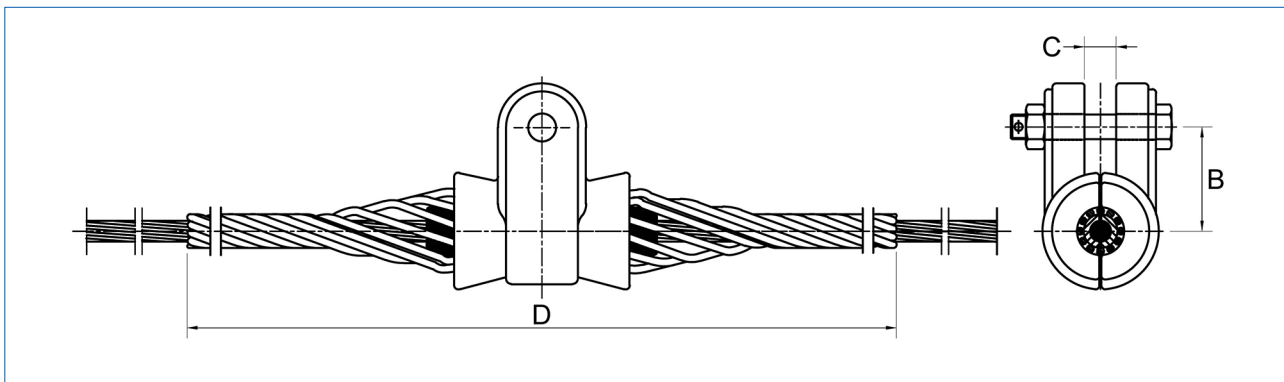

material: aluminium, casted; aluminium, extruded; aluminium-rods; steel, hot dip galvanized; neoprene

L.-Nr.	dimensions in mm					bolt	kN	kA 1s	kg
	cond.Ø	B	C	D					
4361.01/3/A	9,91 - 10,28	55	22	1800	16	50	25	1,20	
4361.02/3/A	10,29 - 10,63	55	22	1800	16	50	25	1,20	

material: aluminium, casted; aluminium, extruded; aluminium-rods; steel, hot dip galvanized; neoprene

L.-Nr.	dimensions in mm					kN	kA 1s	kg
	cond.Ø	B	C	D	bolt			
4361.03/3/A	10,64 - 11,04	55	22	1800	16	50	25	1,40
4361.04/3/A	11,05 - 11,45	55	22	1800	16	50	25	1,10
4361.04/3/AL	11,05 - 11,45	55	22	1800	16	50	25	1,10
4361.05/3/A	11,46 - 11,95	55	22	1800	16	50	25	1,20
4361.05/3/AL	11,46 - 11,95	55	22	1800	16	50	25	1,20
4361.06/3/A	11,96 - 12,23	55	22	1800	16	50	25	1,90
4361.07/3/A	12,24 - 12,69	55	22	1800	16	60	25	1,50
4361.08/3/A	12,70 - 13,02	55	22	1800	16	60	25	1,50
4361.09/3/A	13,03 - 13,48	55	22	1800	16	60	25	1,50
4361.10/3/A	13,49 - 13,78	55	22	1800	16	60	25	1,50
4361.11/3/A	13,79 - 14,11	53	22	1800	16	70	25	1,80
4361.12/3/A	14,12 - 14,57	53	22	1800	16	70	25	2,00
4361.13/3/A	14,58 - 15,10	53	22	1800	16	70	25	2,00
4361.14/3/A	15,11 - 15,41	53	22	1800	16	70	25	1,90
4361.15/3/A	15,42 - 15,74	53	22	1800	16	70	25	2,00
4361.16/3/A	15,75 - 16,40	53	22	2000	16	70	25	2,00
4361.17/3/A	16,41 - 17,11	63	22	2000	16	70	25	2,40
4361.18/3/A	17,12 - 17,54	63	22	2000	16	70	25	2,40
4361.19/3/A	17,55 - 18,05	63	22	2000	16	70	25	2,50
4361.20/3/A	18,06 - 18,58	63	22	2000	16	70	25	2,50
4361.21/3/A	18,59 - 19,07	63	22	2000	16	70	25	2,50
4361.22/3/A	19,08 - 19,52	70	22	2000	16	100	25	4,20
4361.23/3/A	19,53 - 20,21	70	22	2000	16	100	25	3,75
4361.24/3/A	20,22 - 20,95	70	22	2000	16	100	25	4,20
4361.25/3/A	20,96 - 21,48	70	22	2000	16	100	25	4,20
4361.26/3/A	21,49 - 22,11	70	22	2000	16	100	25	4,20

These articles are based on right-hand-layed conductors. Articles for left-hand-layed conductors are available upon request.

These HSU are also available with reinforcing rods upon request.

HSU for ADSS-conductors are available upon request.

Other dimensions are available upon request.

166

Earthwire bracket with parallel groove clamp, double for aluminium based conductors

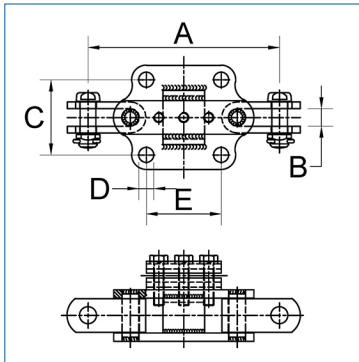

material: aluminium; steel, hot dip galvanized

L.-Nr.	dimensions in mm						bolt	kN	kA 1s	kg
	cond.Ø	A	B	C	D	E				
4652.02	8,2 - 11,7	230	21	90	18	90	19	100	30	3,89
4652.03	11,8 - 15,8	230	21	90	18	90	19	100	20	3,88
4652.04	15,9 - 19,2	230	21	90	18	90	19	100	20	4,05
4652.06/8	17,3 - 19,2	300	20	90	18	90	19	230	40	7,60
4652.06/1	19,1 - 21,0	300	20	90	18	90	19	230	40	7,80
4652.06/2	21,1 - 23,4	300	20	90	18	90	19	230	40	8,37

Earth wire brackets without parallel groove clamps or with parallel groove clamps that are made of other materials and have other hole centres can be delivered upon request.

Fastening screws can be delivered upon request.

Filling pieces for the clamp groove can be delivered, if necessary.

Other types are available upon request.

Earthwire bracket with parallel groove clamp, triple for aluminium based conductors

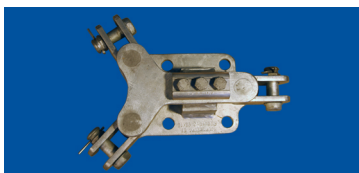
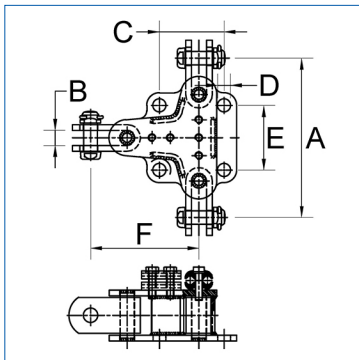

material: aluminium; steel, hot dip galvanized

L.-Nr.	dimensions in mm							bolt	kN	kA 1s	kg
	cond.Ø	A	B	C	D	E	F				
4653.10/1	8,20 - 11,70	222	21	90	18	90	151	19	160	32	5,67
4653.13	11,80 - 15,80	222	21	90	18	90	151	19	160	32	7,60
4653.09/1	15,80 - 19,20	214	21	90	18	90	148	19	160	32	5,85

Earth wire brackets without parallel groove clamps or with parallel groove clamps that are made of other materials and have other hole centres can be delivered upon request.

Fastening screws can be delivered upon request.

Filling pieces for the clamp groove can be delivered, if necessary.

Models with only one parallel groove clamp are available upon request.

Other types are available upon request.

Earthwire bracket with parallel groove clamp, quad for aluminium based conductors

material: aluminium; steel, hot dip galvanized

L.-Nr.	dimensions in mm						bolt	kN	kA 1s	kg
	cond.Ø	A	B	C	D	E				
4653.40/2	8,20 - 11,70	252	21	90	18	90	19	160	32	6,60
4653.40	11,80 - 13,00	252	21	90	18	90	19	160	32	6,62
4653.0001	15,90 - 19,20	252	21	90	18	90	19	160	32	5,80
4653.40/1	19,30 - 24,60	252	21	90	18	90	19	160	32	7,00

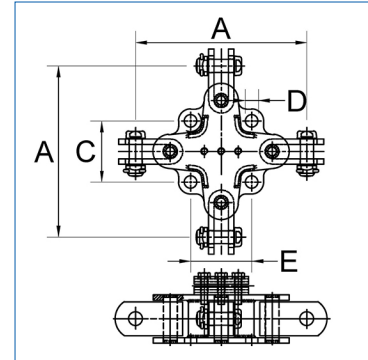

Earth wire brackets without parallel groove clamps or with parallel groove clamps that are made of other materials and have other hole centres can be delivered upon request.

Fastening screws can be delivered upon request.

Filling pieces for the clamp groove can be delivered, if necessary.

Other types are available upon request.

Shunt copper, insulated

material: high flexible copper wire, insulated; copper, tinned; steel, hot dip galvanized

L.-Nr.	dimensions in mm		cross section sq mm	screw	kA 1s	kg
	A	B				
4664.01/3A	500	17	70	M12 X 30	14	0,60
4664.01/5A	1000	17	70	M12 X 30	14	1,00
4664.01/6A	1500	17	70	M12 X 30	14	1,30
4664.31/1A	500	17	95	M12 X 35	19	0,72

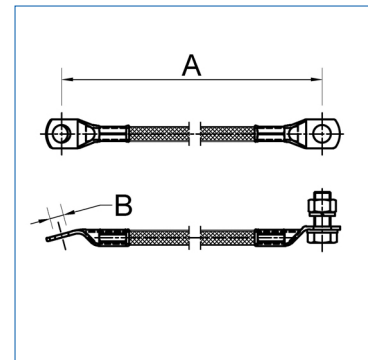

Other lengths and connections are available upon request.



168

Shunt copper, with connection screw for clamps

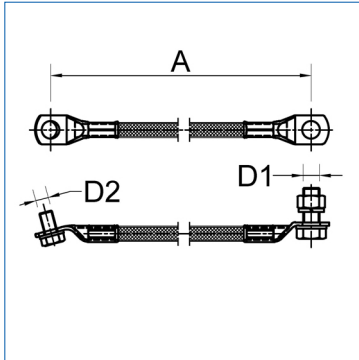

material: high flexible copper wire, insulated; copper, tinned

L.-Nr.	dimension in mm	cross section sq mm	D1	D2	kA 1s	kg
	A					
4664.03	500	70	M12 X 35	M12 X 20	14	0,61
4664.31/1	500	95	M12 X 35	M12 X 20	19	0,75

Other lengths and connections are available upon request.

Shunt aluminium

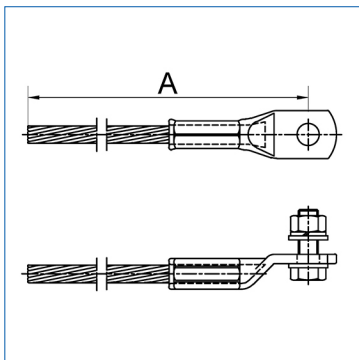

material: aluminium; steel, hot dip galvanized

L.-Nr.	dimension in mm	cross section sq mm	screw	kA 1s	kg
	A				
4664.35	500	70	M12 X 35	8	0,20
4664.35/1	1000	70	M12 X 35	8	0,30
4664.36	1000	95	M12 X 35	11	0,39
4664.0004	1000	95	M12 X 35	11	0,44
4664.36/1	1500	95	M12 X 35	11	0,60
4664.45	1000	120	M12 X 35	14	0,45
4664.45/10	1500	120	M12 X 35	14	0,70

Other lengths and connections are available upon request.

Heliformed dead end with thimble and reinforcing rods for aluminium based conductors

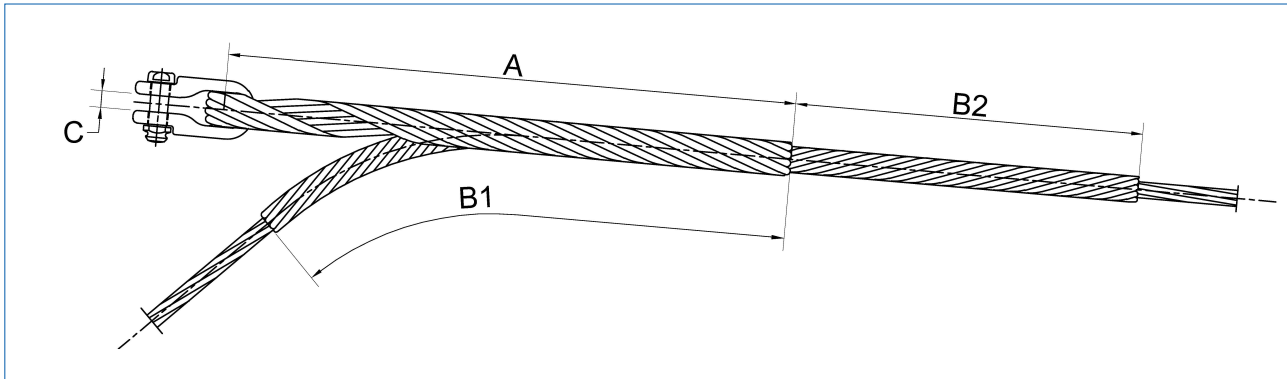

material: aluminium, casted; steel, hot dip galvanized

L.-Nr.	cond.Ø mm	dimensions in mm				kg
		A	B1	B2	C	
4480.06	7,25 - 8,53	870	1800	450	20	1,80
4480.03	8,54 - 10,45	900	1800	430	20	2,00
4480.00	10,47 - 11,50	1000	2000	475	20	2,40
4480.01	11,51 - 12,50	1200	2200	407	20	2,80
4480.02	12,51 - 13,26	1200	2500	573	20	3,50
4480.04	13,27 - 14,50	1500	2500	435	20	5,24
4480.05	14,51 - 15,50	1500	2900	533	20	5,03
4480.07	15,51 - 16,80	1600	3000	514	20	5,58
4480.08	16,81 - 17,80	1600	3000	550	20	5,90
4480.09	17,81 - 18,50	1700	3000	464	20	6,14
4480.10	18,51 - 19,70	1900	3000	550	20	8,36
4480.11	19,71 - 21,28	2000	3300	650	20	9,23
4480.12	21,29 - 22,00	2200	3300	513	20	10,18
4480.13	22,01 - 23,00	2200	3500	645	20	10,90
4480.14	23,01 - 23,60	2200	3500	675	20	10,90
4480.15	23,61 - 24,40	2400	3500	574	20	12,20
4480.16	24,41 - 25,30	2400	3500	608	20	12,40
4480.18	26,21 - 27,20	2400	3500	670	20	12,60

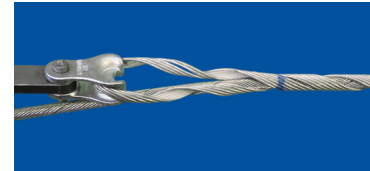

These articles are based on right-hand-layed conductors. Articles for left-hand-layed conductors are available upon request.

Dead ends for ACS-strands in the outer layer are available upon request.

Dead Ends for ADSS-conductors are available upon request.

Other dimensions are available upon request.

170

Stockbridge damper with casted clamp for aluminium based conductors

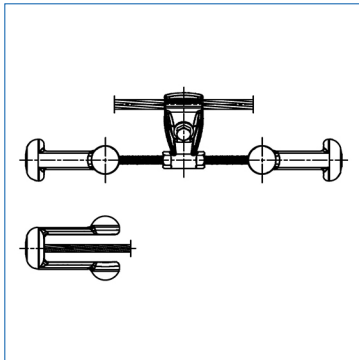

material: aluminium, casted; steel, hot dip galvanized; cast iron, hot dip galvanized

L.-Nr.	dimensions in mm		version	kg
	cond.Ø	screws		
9301.01/G/1	7,0 - 14,0	M10	1	1,70
9301.0010	7,0 - 14,0	M10	2	1,50
9303.01/G/1	7,0 - 14,0	M10	2	2,10
9301.03/G/1	14,0 - 16,5	M10	1	1,74
9303.03/G/1	14,0 - 16,5	M10	2	2,20
9303.04/G/1	14,0 - 19,0	M12	2	2,23
9301.04/G/1	16,6 - 19,0	M10	1	1,80
9301.020/G/1	19,0 - 29,0	M14	1	2,10
9304.021/G/1	19,0 - 29,0	M14	1	4,20
9306.03/G/1	19,0 - 29,0	M14	1	6,00
9303.006/G/1	19,0 - 29,0	M14	2	2,50
9305.06/G/1	19,0 - 29,0	M14	2	5,00
9304.10/G/1	28,5 - 41,0	M14	1	4,22
9306.07/G/1	28,5 - 41,0	M14	1	6,10
9303.10/G/1	28,5 - 41,0	M14	2	2,60
9305.07/G/1	28,5 - 41,0	M14	2	5,25

Version 1 covers two resonant frequencies and **version 2** covers four resonant frequencies.

The weights are casted onto the messenger wire. Models with compression sleeve are available upon request.

Models with stainless steel messenger wire are available upon request.

Other types are available upon request.

Stockbridge damper with forged clamp for aluminium based conductors

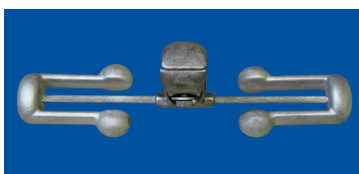
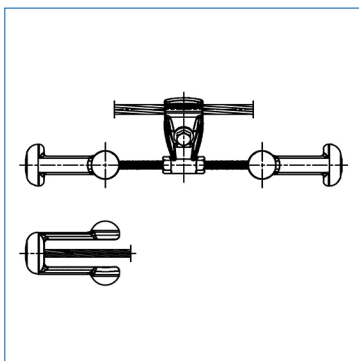

material: aluminium, forged; steel, hot dip galvanized; cast iron, hot dip galvanized

L.-Nr.	dimensions in mm		version	kg
	cond.Ø	screws		
9301.020/EA1	11,0 - 14,5	M10	1	1,50
9303.020/EA1	11,0 - 14,5	M10	2	2,10
9301.030/EA1	14,5 - 17,0	M10	1	1,59
9303.030/EA1	14,5 - 17,0	M10	2	2,05
9301.040/EA1	17,0 - 19,5	M10	1	1,57
9301.050/EA1	19,5 - 22,0	M12	1	1,65
9304.050/EA1	19,5 - 22,0	M12	1	3,95
9303.050/EA1	19,5 - 22,0	M12	2	2,05
9301.060/EA1	22,0 - 24,5	M12	1	1,79
9304.060/EA1	22,0 - 24,5	M12	1	3,80
9303.060/EA1	22,0 - 24,5	M12	2	2,14
9301.070/EA1	24,5 - 28,0	M12	1	1,91
9304.070/EA1	24,5 - 28,0	M12	1	4,00
9303.070/EA1	24,5 - 28,0	M12	2	2,36
9304.080/EA1	28,0 - 31,0	M12	1	4,00

material: aluminium, forged; steel, hot dip galvanized; cast iron, hot dip galvanized

L.-Nr.	dimensions in mm		version	kg
	cond.Ø	screws		
9303.080/EA1	28,0 - 31,0	M12	2	2,20
9304.090/EA1	31,0 - 33,0	M12	1	4,00
9306.090/EA1	31,0 - 33,0	M12	1	6,00
9303.090/EA1	31,0 - 33,0	M12	2	2,40
9304.100/EA1	33,0 - 35,0	M12	1	4,10
9303.100/EA1	33,0 - 35,0	M12	2	2,60
9304.110/EA1	35,0 - 38,0	M12	1	4,32
9306.110/EA1	35,0 - 38,0	M12	1	6,20
9308.110/EA1	35,0 - 38,0	M12	1	8,10
9304.120/EA1	38,0 - 42,0	M12	1	4,10
9306.120/EA1	38,0 - 42,0	M12	1	6,00
9304.130/EA1	42,0 - 46,0	M12	1	4,10
9306.130/EA1	42,0 - 46,0	M12	1	6,00

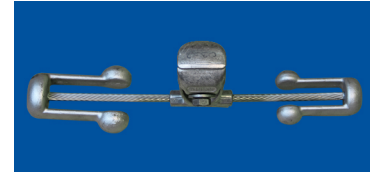

Version 1 covers two resonant frequencies and **version 2** covers four resonant frequencies.

The weights are casted onto the messenger wire. Models with compression sleeve are available upon request.

Models with stainless steel messenger wire are available upon request.

Other types are available upon request.

Down lead clamp

material: aluminium; steel, hot dip galvanized

L.-Nr.	dimensions in mm			fixing bolt	kg
	cond.Ø	A	C		
4680.27	8,2 - 11,7	40	22	M8	0,35
4680.27/01	11,8 - 13,0	40	22	M8	0,40
4680.27/04	13,1 - 14,4	40	22	M8	0,42
4680.27/1	14,5 - 16,0	40	22	M8	0,42
4680.27/1/1	15,9 - 17,4	40	22	M8	0,42
4680.27/2	17,5 - 19,2	40	22	M8	0,70

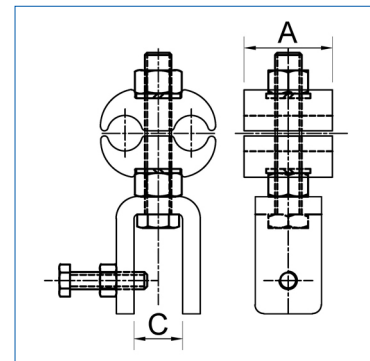

172

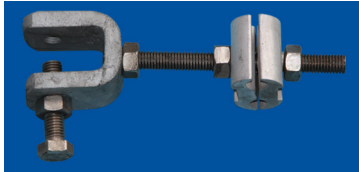

material: aluminium; steel, hot dip galvanized

L.-Nr.	dimensions in mm			fixing bolt	kg
	cond.Ø	A	C		
4680.27/2/1	19,3 - 21,2	40	22	M8	0,46
4680.27/2/3	21,3 - 22,8	40	22	M8	0,46
4680.27/2/2	22,9 - 24,6	40	22	M8	0,52

Down lead clamps will be used to fix the fibre optic cable to be led off on the corner leg of the tower. When doing so, it will be particularly important to adapt the groove to the diameter of the OPGW-earthwire. There are many special models. Some examples:

The clamps will be mounted while offsetting them by different angles, which range up to 90°. For this purpose, the clamps will be provided with a replaceable clamping bolt, which can optionally also be installed with an offset of 90°.

Fastening with other screwing systems or stainless screws as well as ribbons also is possible. Clamps serving for fastening on towers made of wood or concrete also are obtainable.

Clamps with insulating sleeves that will, in connection with an insulating set for the earthwire tension brackets, make it easier to measure the earthing resistance can be purchased upon request.

Clamps with one-sided filling pieces are obtainable upon request.

Other dimensions are available upon request.

Heliformed spiral vibration damper

for all materials

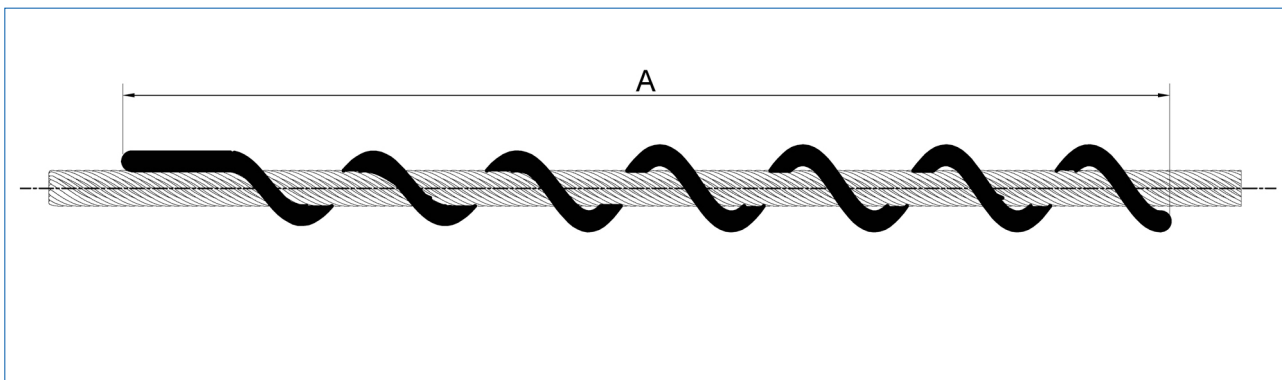

material: PVC

L.-Nr.	dimensions in mm		kg
	cond.Ø	A	
9320.04	6,35 - 8,30	1240	0,30

material: PVC

L.-Nr.	dimensions in mm		kg
	cond.Ø	A	
9320.05	8,31 - 11,72	1300	0,28
9320.06	11,73 - 14,32	1345	0,32
9320.07	14,33 - 19,30	1615	0,93

Spiral dampers are particularly suitable for damping the high-frequent vibrations of thin OPGW's (optical ground wires). Assembly will be done right after the end of the fittings.

Other dimensions are available upon request.