

Contents

General	5
U-bolt	12
Suspension hinge with bolt	12
Suspension hinge with damping straps, for rigid V-strings	13
Strain hinge with bolt	13
Universal joint with bolt	14
Hinge pull-out safe, with additional washers	14
Straight shackle	15
Straight bow shackle	15
Twisted shackle	16
Twin ball pin, according to IEC	16
Twin ball pin, according to ÖNORM	17
Twin ball pin with arcing device attachment, according to IEC	17
Twin ball pin with arcing device attachment, according to ÖNORM	18
Ball eye, according to IEC	18
Ball eye, according to ÖNORM	19
Ball eye long type, according to IEC	19
Oval ball eye , according to IEC	20
Oval ball eye with collar, according to IEC	20
Oval ball eye straight, with arcing device attachment, according to IEC	21
Oval ball eye straight, with arcing device attachment, according to ÖNORM	22
Oval ball eye straight, with arcing device attachment, long type, according to IEC	22
Oval ball eye straight, with arcing device attachment, long type, according to ÖNORM	23
Oval ball eye straight, with arcing device attachment, according to IEC	23
Ball eye twisted, with arcing device attachment, according to IEC	24
Ball eye twisted, with arcing device attachment, according to ÖNORM	25

02

Ball eye twisted, with arcing device attachment, long type, according to IEC.....	25
Ball eye twisted, with arcing device attachment, long type, according to ÖNORM.....	26
Oval ball eye twisted, with arcing device attachment, according to IEC.....	26
Ball clevis, according to IEC.....	27
Ball clevis with arcing device attachment, straight, according to IEC.....	27
Ball clevis with arcing device attachment, twisted, according to IEC.....	28
Socket eye casted, according to IEC.....	28
Socket eye forged, according to IEC.....	29
Socket tongue casted, straight, with arcing horn attachment, according to IEC.....	29
Socket tongue forged, straight, with arcing horn attachment, according to IEC.....	30
Socket tongue forged, straight, with arcing horn attachment, according to ÖNORM.....	30
Socket tongue casted, with arcing device attachment, twisted, according to IEC.....	31
Socket tongue forged, with arcing device attachment, twisted, according to IEC.....	31
Socket tongue forged, with arcing device attachment, twisted, according to ÖNORM.....	32
Socket clevis casted, according to IEC.....	32
Socket clevis forged, according to IEC.....	33
Socket clevis casted, with arcing device attachment, twisted, according to IEC.....	33
Double eye straight.....	34
Double eye twisted, forged.....	34
Double eye twisted, flat steel.....	35
Oval double eye twisted, flat steel.....	35
Double eye with arcing device attachment, straight.....	36
Double eye with arcing device attachment, twisted.....	36
Double eye straight, with arcing device attachment, connection twisted.....	37
Oval double eye with arcing device attachment, straight.....	37
Oval double eye straight, with arcing device attachment, connection twisted.....	37
Oval double eye with arcing device attachment, twisted.....	38
Double straps.....	38
Clevis eye straight.....	39
Clevis eye straight, riveted.....	40

Clevis eye straight, welded	40
Clevis eye twisted, forged.....	41
Clevis eye with arcing device attachment, straight, forged	42
Clevis eye with arcing device attachment, twisted, forged.....	42
Adjustable extension link straight.....	43
Adjustable extension link twisted	43
Sag adjuster.....	44
Turnbuckle eye-eye	44
Turnbuckle eye-clevis.....	45
Turnbuckle clevis-clevis.....	45
Triangular yoke bended	46
Triangular yoke welded.....	46
Triangular yoke plate	47
Triangular frame yoke with straps.....	48
Trapezoidal yoke bended	48
Trapezoidal yoke welded	49
Trapezoidal yoke plate	49
Yoke for triple bundle, v-string	50
Yoke for triple bundle, i-string	50
Yoke for quad bundle, v-string	51
Yoke for quad bundle, i-string	51
Yoke plate with damping straps, for rigid V-strings.....	52
Yoke plates, for V-strings, inverse V-strings and Y-strings	52
Triangular yoke with a damping tongue, for suspension strings.....	53
Frame yoke with a damping tongue, for tension strings.....	53
Shifting yoke in trapezoidal and triangular form, for tension strings.....	54
Displacement yoke with damping elements, for tension strings, for all conductor configurations.....	54
Yoke with hinge for tension strings, for connecting a triple bundle with a double string.....	54
Rotary spacer with damping links, for suspension strings with horizontal twin bundle conductors and for four bundle conductors	55

04

Flapping yoke for suspension strings, for connecting a triple bundle to a double string	55
Unhingeable yoke with slots on the side, for suspension strings, for all conductor configurations.	55
Yoke with shifting slots, with displacement elements for tension strings, for all conductor configurations .	56

General

String hardware offered in this part of the catalogue are made up of **fittings connecting insulators with the towers and conductors** under mechanical load.

Clevis-eye connections and ball and socket connections are standardized internationally according to the following Standards:

IEC 60120, Dimensions of ball and socket couplings of string insulator units

ÖNORM E 4104, Electrical overhead lines; ball and socket; coupling dimensions (for Ball 16 and 20)

ANSI C 29.2 / 52-3 for Ball 16

/ *52-5* for Ball 18

/ *52-8* for Ball 22

IEC 60372, Locking devices for ball and socket couplings of string insulator units - Dimensions and tests

IEC 60471 and *DIN 48074*, Eyes and clevises; connecting dimensions

DIN 48073, Connecting bolts for overhead power lines

Oval eyes and Y connections according to *EN 61466*, Composite string insulator units for overhead lines with a nominal voltage greater than 1 kV - or specific requirements

DIN 48068, Protective fitting attachment; for overhead lines, connection dimensions

For ball 24, the arcing devices will be fixed with 2 screws M14 at a distance of 32 mm because of the short circuit currents that may occur. Fastening using two screws is also possible according to **Swiss and Italian Standards**.

Material

In order to withstand the static as well as dynamic loads acc. to *EN 50341*, heat treated steels will be used for the string hardware as follows:

- steels for quenching and tempering acc. to *DIN EN 10083*;
- structural steels (nitriding steels) for hinges, links and yokes acc. to *DIN EN 10025*;
- malleable cast acc. to *DIN EN 1562* and spheroidal graphite cast (ductile iron) acc. to *DIN EN 1563* for some socket fittings;
- **For special cases where high dynamic loads may occur at low temperatures, fittings made of low-temperature (cryogenic) steels are available.**
- Stainless steels are occasionally used in regions with a corrosive atmosphere, e.g. near the sea.
- Screw bolts according to *DIN 48073*
- Split pins for screw bolts are made of stainless steel.
- Security split pins acc. to *IEC 60372*- Locking devices for ball and socket couplings of string insulator units, Dimensions and tests for socket fittings - are also made of stainless steel or optionally made of copper and tin-plated.

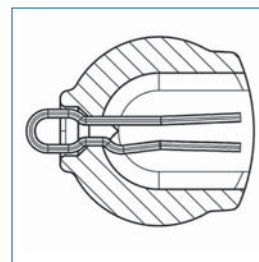

Security split pin inserted in the socket eye

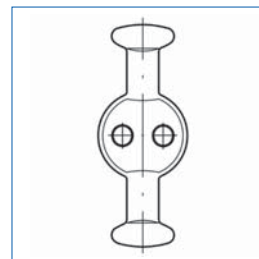

Connections for Ball 24 and 28 as well as for ball couplings according to Swiss Standards

06

- All socket fittings are equipped with security split pins
- All fittings made of steel will be **hot dip galvanized** acc. to *IEC 61284* or *EN ISO 1461* - Overhead lines, Requirements and tests for fittings - unless they are stainless steel. Connecting elements will be hot dip galvanized acc. to *EN ISO 10684* or *ASTM 153* - Fasteners, Hot dip galvanized coating).

For projects with an aggressive atmosphere, the minimum zinc thickness of fittings can be increased from 85 μ to 110 μ or 130 μ Microns.

All fitting assemblies supplied have identification marking acc. to *IEC 61284*; this includes manufacturers mark and date code, specified minimum failure load, and one second short circuit current withstand rating.

Short circuit protection of the string hardware does not only depend on the corresponding cross sections but also on the surface quality of the connections, including mechanically loaded bolts. In general, a current density of 70 A/mm² can be expected. In this respect, heating will remain below 400°C at an ambient temperature of 35°C, which is why there will not be any inadmissible loss of cohesion of the string hardware.

As for ball eyes where arcing devices can be fixed, the stated value will

only be applicable if arcing devices are actually used. If the short circuit currents are very high, it will be possible to provide for by-passing using a shunt. For this purpose, the fittings concerned will have connecting eyes with suitable holes.

As for hinged connections established by using screw bolts, the short circuit value will not only be determined by the bolt diameter but also by the mechanical load.

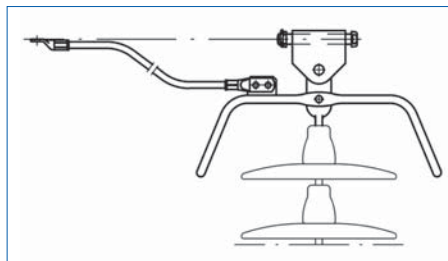

Shunt for high short circuit currents

Screw Bolt:

- 19 mm: One second short circuit current 40 kA
- 22 mm: One second short circuit current 50 kA
- 25 mm: One second short circuit current 63 kA

Due to their punctiform coupling, U bolts, shackles and oval eyes have lower short circuit values and are less suitable for high electric loads.

The short circuit behaviour of insulator strings will be checked acc. to *IEC 61467*- Insulators for overhead lines, Insulator strings and sets for lines with a nominal voltage greater than 1000 V, AC power arc tests. In this context, it should be noted that a remaining force needs to be guaranteed after the power arcs. The values stated in the tables refer to this standard also.

If stainless steels are used, a reduced short circuit resistance needs to be expected.

Anti rotation protection

In case of multi-link insulator strings with porcelain long rod insulators, rotation of individual insulators can lead to faulty positions of the arcing devices. In order to prevent this, different ball fittings and double balls are equipped with anti rotation protection.

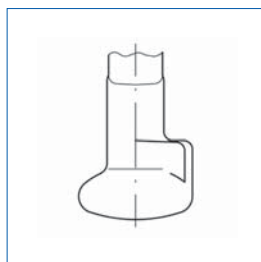

Anti rotation protection on ball fittings

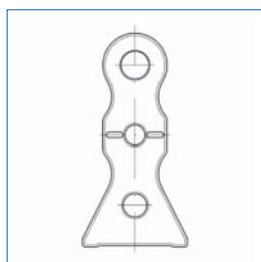

Double eyes with anti rotation protection

Rigid V strings with a small angular position, which can also be used for lightweight angular towers, need anti rotation protection. For this purpose, there are double eyes with a straight end for porcelain long rod insulators.

Hot line work

For work using insulated rods, ball eyes, socket eyes and double eyes with collars can be used to apply the tools. For this purpose, yokes are provided with additional holes or are given a shape corresponding to the insulated tools.

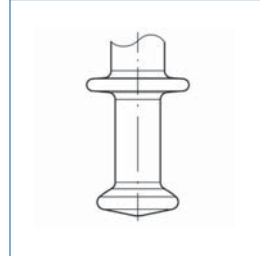

Ball eye for hot line work

Yokes

The yokes, which serve for spacing multiple strings, will be given their shape depending on the conductor configuration used. This configuration can consist of a single conductor, twin bundle, triple bundle, four bundle, six bundle or eight bundle. As for multiple strings with two-point fastening on the tower, maximum displacement due to wind will have to be considered.

If a low vertical load, which is caused by conductor routing, accompanies wind load, the displacements can reach 60° and more. In this respect, the fact that the strings will be displaced less is the result of the calculation of conductor displacements having already been taken into account.

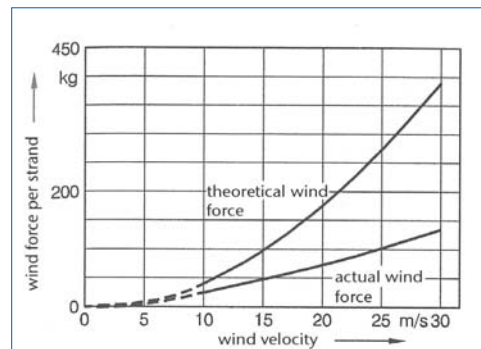

Theoretical and actual string displacement acc. to Kissling

Conductor displacement can be slightly restricted by placing counterweights. However, the arcing devices and yokes will impede each other. Therefore, it will be necessary to provide the yoke with a recess or to design the arcing device as to make sure that it will pass the yoke in the displaced state.

Load transposition

According to *EN 50341*, Overhead electrical lines exceeding AC 45 kV - Part 1: General requirements - Common specifications, it is also required to consider a dynamic load as it will, e.g., occur on multiple strings **if one insulator string breaks**.

The remaining strings must be capable of controlling the high dynamic longitudinal and transverse forces.

This load transposition occurs as a pulse-like shock process that implies violent oscillating movements and is, as a rule, excluded after about 200 ms. As a result of this load transposition, the bending and tensile stresses will be increased significantly.

This can lead to the failure of the whole insulator string.

This mainly occurs on multiple strings with **porcelain long rod insulators**, which are very sensitive to bending loads. The fact that the broken string knocks into the intact one can cause this string to be damaged or to break.

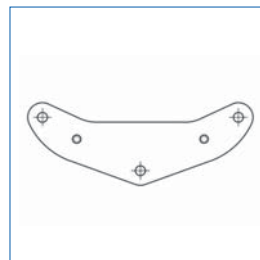

Yoke for a big string displacement

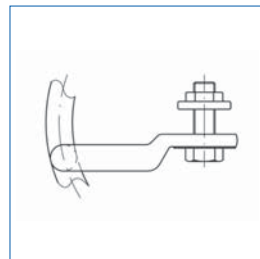

Arcing device for a big string displacement

08

As for **composite insulators**, higher longitudinal tensile forces will be caused by the flexibility of the glass fibre rods. However, the bending stress can be neglected.

Cap and pin type insulators are less critical. As they are short and their connections are so flexible, the bending stresses can remain small. Uncontrolled impact by the broken string can lead to damage of the insulator sheds. In general, however, this will not cause the whole string to break.

Design criteria for insulator strings

Calculations and tests have helped to obtain some important rules for designing multiple insulator strings especially for porcelain long rod insulators:

- All the partial strings are to be fixed separately.
- The distance of the insulator strings on their live ends is to be as small as possible. A slight inclination will help to prevent the insulator strings from knocking one into the other.
- The yokes should be as high as possible. This is no problem for tension strings. As for suspension strings, the electrical requirements relating to the minimum distance will have to be considered.
- If there are several shorter insulators, their bending moments will be smaller. This will have positive effects. For the reasons above, this measure can be implemented on tension strings more easily.

Triangular frame yoke

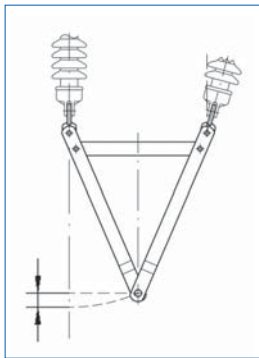

Yoke with displacement elements

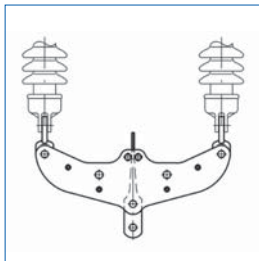

Displacement yoke for suspension strings

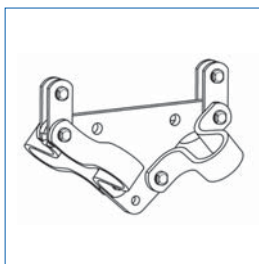

Displacement yoke for tension strings

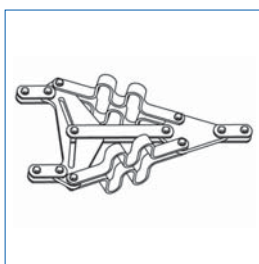

There are cases where these measures won't be sufficient so that additional precautions will have to be taken:

- Additional masses mounted on the insulator string can be used to decelerate the load transposition process and thus reduce strains and stresses acting on the insulator. In most cases, these masses will be mounted on the yoke. In any case, the effect of these additional masses should be verified.
- **Damping elements**
These elements are based on the fact that special displacement elements, which are displaced plastically at load transposition, will lead to power dissipation. These elements will be mounted on the hinged connections of the string, primarily in the yoke hinges.

The patented **Mosdorfer Damping Systems (patent Müller)** are a special group enabling highly effective reduction of stresses and strains that are inadmissibly high, the yoke as a whole being the displacement element.

- This combination of yokes is stiff enough to act as a stable yoke at normal operation.
- After one string has broken, the yoke as a whole will be displaced.
- Energy consumption is much higher than that of single displacement elements.
- These systems can be used for all possible string configurations and conductor combinations.
- The yokes being displaced at a rupture are stable enough to withstand wind displacements of up to 45° and more without being damaged.

At normal operation, the generation of yokes described here will establish a stable connection between the insulators. A short time after the rupture, the rigid-body connection will have disintegrated. Now the conductors are only connected via the yoke by a component that is pliable and strongly expandable and absorbs the shock in a gentle and resilient manner.

If one string breaks, the yoke will, in the case of **suspension strings**, be released from a certain rotation thanks to the **technology of unhinging via side slots**. Thus the conductors will only be connected to the intact string by a pliable displacement element.

As for the **tension strings**, a bolt will move **along a slot**, one displacement element being expanded and the other one being compressed.

After the yoke has largely turned in the direction of the force, the conductor force will run over the displacement element that is almost completely expanded.

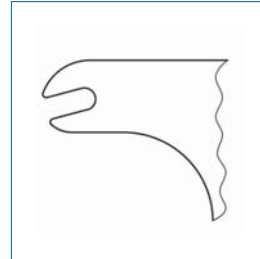

Yoke for suspension strings with an unhingeable yoke on the side

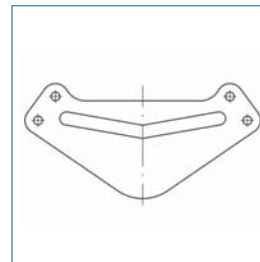

Yoke for tension strings with a sliding slot

Computational simulation of load transposition

For a long time, Mosdorfer has used a computational programme suitable for double tension and suspension strings, including V-strings, Y-strings and inverse V-strings for all conductor configurations.

It is also possible to quantitatively analyse the hinged connections in a string (ball and socket connections or eye-clevis connections).

Furthermore, so-called trapezoidal double yokes can be integrated in the computational programme.

The chronological sequence of string vibration, including data about the respective tensile stresses or tensions on the intact insulators, is calculated.

These values will be used to assess how likely it is that the insulator string would break.

With 1:1 tests, these essentially cheaper calculations show a good congruence.

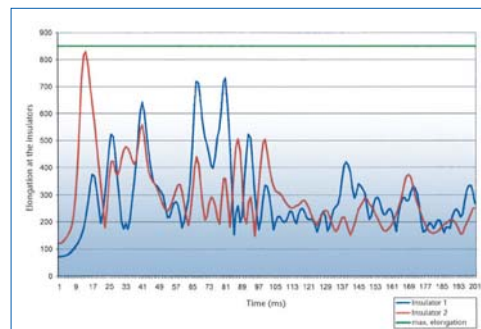

Chronological sequence of elongation in the intact string

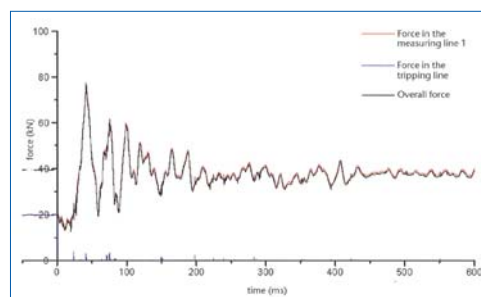

Chronological sequence of tensile force in the intact string

Simulation for double strings with displacement elements

Provided that the displacement elements are connected in a hinged manner and are exclusively subjected to tension or pressure, the characteristic operating curves of the programme can then be the basis of the analysis.

The ratio between prolongation of elements and displacement force has a characteristic shape so that it is accessible to mathematical modelling.

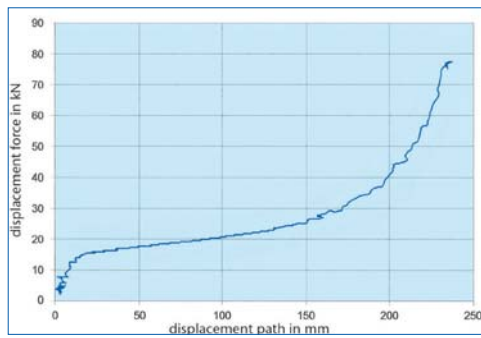

Example of the operating line of the displacement element

These values will be obtained from static and dynamic tests. Tests have also been made at low temperatures.

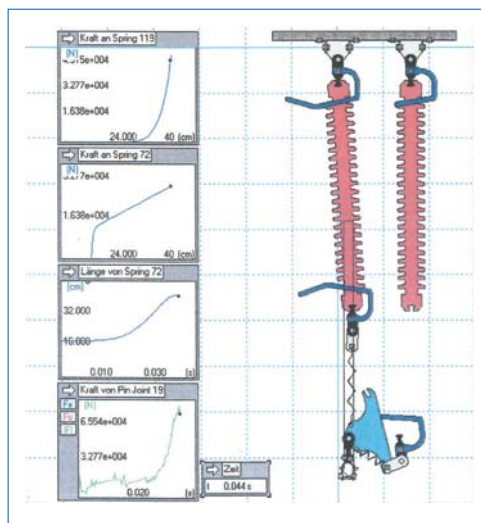

Unhingeable yoke: Position of the string after one partial string has broken

The following charts show the time dependent curves for elongation and tensile force and will then demonstrate the load transposition process.

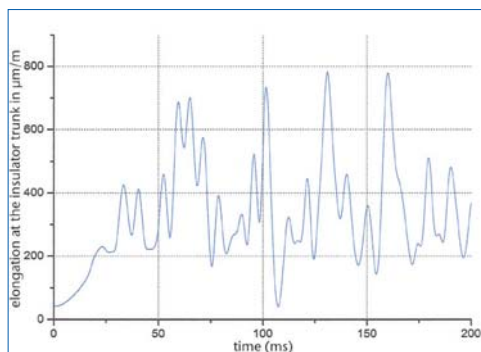

Chronological sequence of elongation based on a displacement element (left) and Chronological sequence of tensile force based on a displacement element (right)

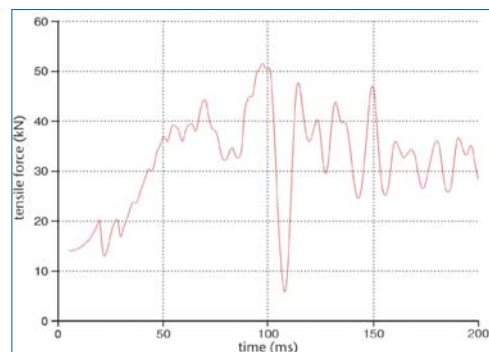

time (ms)
tensile force (kN)

Rigid V-strings are intended for suspension towers and angle towers with angles of up to 10°. Due to the damping system based on the suspension hinges and yoke plates with anti rotation protection, loads with a high horizontal predominance can also be controlled.

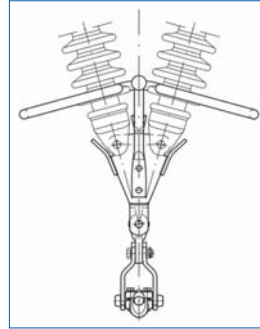

Yoke plate of a V-string with damping eyes

Inverse V-strings are fit for load transposition and can thus be equipped with special rigid connecting elements. These strings can also be dimensioned by using the computational programmes of MOSDORFER.

As for further information on the topic variety of yokes that are suitable for load transposition, please refer to the respective chapters.

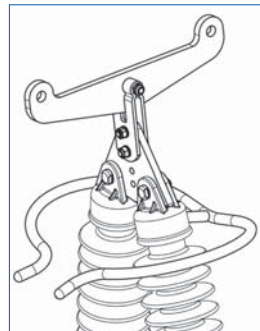

Inverse V-string

For upgrading lines from, e.g., 220 kV to 380 kV, **insulating crossarms** will often be used.

The yokes connecting the tension insulators to the post insulators will have to be specially adapted and will, in any case, have to be dimensioned separately.

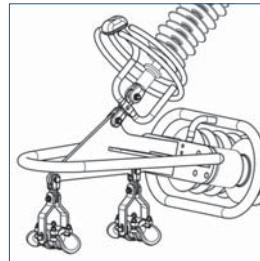

Yoke for the insulating crossarm

An example can be found in the relevant part of the catalogue.

12

U-bolt

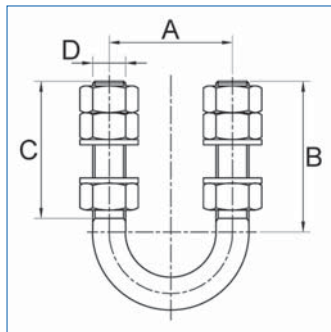

material: steel, hot dip galvanized

L.-Nr.	dimensions in mm				kN	version	kg
	A	B	C	D			
4104.20/30	60	150	75	16	180	2	0,73
4104.20/33	60	240	120	16	180	2	0,89
4104.33/1	60	220	110	18	200	2	1,30
4104.34/1	60	200	100	20	200	2	1,40
4104.34/13	70	110	90	20	200	1	1,06
4104.22/9	80	100	90	20	200	1	1,06
4104.22/81	100	100	90	20	200	1	1,10
4104.25/3	70	160	80	22	220	2	1,60
4104.24/3	90	125	100	24	280	1	1,86

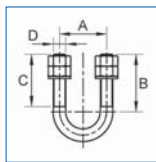

Version 1 has six nuts and **version 2** has four nuts.

Other dimensions are available upon request.

Suspension hinge with bolt

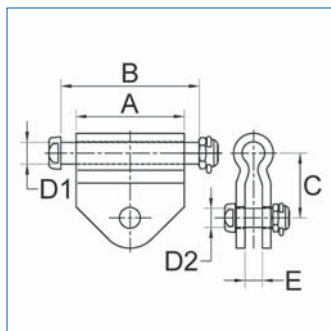

material: steel, hot dip galvanized

L.-Nr.	dimensions in mm						kN	kA 1s	kg
	A	B	C	D1	D2	E			
4181.00/S	60	90	65	19	19	20	150	32	1,12
4181.02/S	75	105	65	19	19	20	200	40	1,56
4181.02/0/S	75	115	65	19	19	20	200	40	1,58
4181.41/S	75	110	75	25	19	20	160	40	1,70
4181.12	75	110	75	25	22	20	280	50	2,40
4181.03	95	125	65	19	19	20	150	30	1,45
4181.04	95	125	65	19	19	20	200	40	1,84
4181.19/3	95	130	75	22	22	20	240	50	2,64
4181.43	95	130	75	25	19	20	200	40	2,33
4181.14	95	130	75	25	22	20	280	50	2,87
4181.05	110	145	65	19	19	20	200	40	1,90
4181.08	130	155	65	19	19	20	160	40	2,20
4181.07/S	155	185	65	19	20	20	200	40	2,44

Other dimensions are available upon request.

Suspension hinge with damping straps

for rigid V-strings

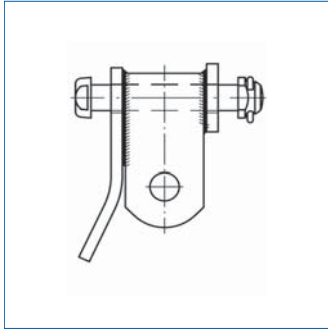

Rigid V-strings will be used for suspension towers and angle towers with angles of up to 10°.

Thanks to the damping system based on the suspension hinges and the yoke plate, loads with a high horizontal predominance can also be controlled.

Strain hinge with bolt

material: steel, hot dip galvanized

L.-Nr.	dimensions in mm						kN	kA 1 s	kg
	A	B	C	D1	D2	E			
4180.02/S	70	105	65	19	19	20	200	40	1,51
4180.04/S	90	125	65	19	19	20	200	40	1,77
4180.12/S	90	130	75	25	19	20	240	40	2,67
4180.22	90	130	75	25	22	20	280	50	2,86
4180.05/S	110	145	65	19	19	20	200	40	2,04
4180.05/4	110	145	75	22	19	20	230	40	2,30
4180.13/S	110	150	75	25	19	20	240	40	3,07
4180.23	110	150	75	25	22	20	280	50	3,27
4180.06/S	130	165	65	19	19	20	200	40	2,27
4180.07/S	150	185	65	19	19	20	200	40	2,65
4180.15/S	150	190	75	25	19	20	240	40	3,96
4180.08/S	170	205	65	19	19	20	200	40	3,05
4180.16/S	170	210	75	25	19	20	240	40	4,00

Other dimensions are available upon request.

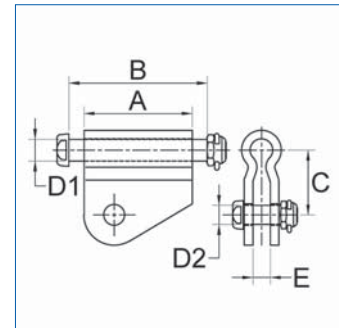

14

Universal joint with bolt

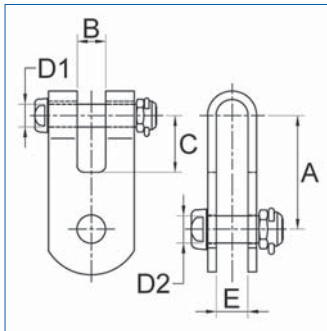

material: steel, hot dip galvanized

L.-Nr.	dimensions in mm						kN	kA 1s	version	kg
	A	B	C	D1	D2	E				
4170.60	80	20	40	19	19	20	160	40	1	1,15
4170.60/1	80	22	40	19	19	20	230	40	1	1,18
4170.75/4	80	24	55	22	19	20	160	40	2	1,20
4175.09/2	80	24	55	25	19	20	160	40	2	1,30
4170.73/1	90	20	40	22	22	25	230	40	1	1,46
4170.72/4/1	90	25	55	22	22	24	320	50	1	1,80
4175.09/3	90	24	55	25	22	20	320	50	2	1,80

Version 2 is pull-out safe.

Other dimensions are available upon request.

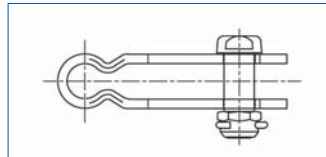

Hinge pull-out safe, with additional washers

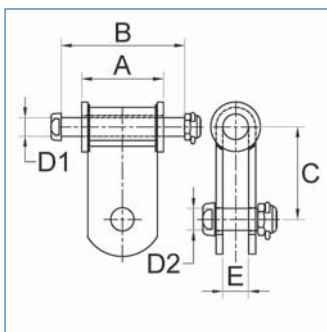

material: steel, hot dip galvanized

L.-Nr.	dimensions in mm						kN	kA 1s	kg
	A	B	C	D1	D2	E			
4181.38	100	130	65	19	19	20	200	40	1,84
4181.39/1	100	120	80	20	19	22	120	40	1,60
4181.40/1	100	133	80	20	22	22	120	40	2,45
4181.0087	115	136	80	20	19	22	120	40	2,10
4181.39	115	136	80	20	19	22	120	40	2,60
4181.40	115	136	80	20	22	22	120	40	2,67
4181.0086	115	136	80	20	22	22	200	40	3,15
4181.42	120	152	80	30	22	32	280	50	6,10
4181.39/2	195	205	80	20	19	22	120	40	3,00

The articles with D1 = 20/ 30 mm are assembled with a screw instead of a screw bolt.

Other dimensions are available upon request.



Straight shackle

material: steel, hot dip galvanized

L.-Nr.	dimensions in mm			bolt	kN	kg
	A	B	C			
4250.0030	100	24	16	16	120	0,59
4250.0025	75	24	19	19	180	0,80
4250.0032	75	24	19	19	240	0,90
4250.08/5	71	22	20	19	120	0,70

Other dimensions are available upon request.

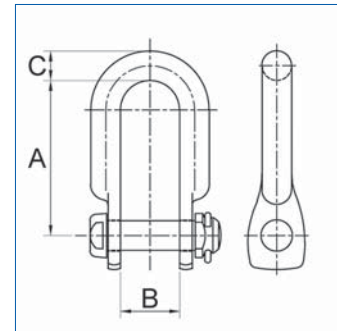

Straight bow shackle

material: steel, hot dip galvanized

L.-Nr.	dimensions in mm			bolt	kN	kg
	A	B	C			
4250.0026	80	20	16	16	120	0,55
4250.0029	80	20	16	19	130	0,60
4250.0028	100	20	19	19	240	0,97

Other dimensions are available upon request.

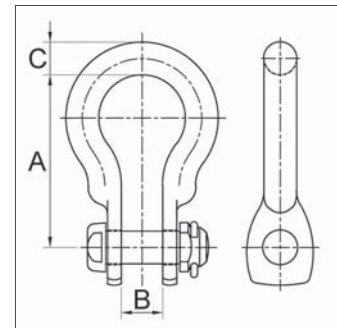

16

Twisted shackle

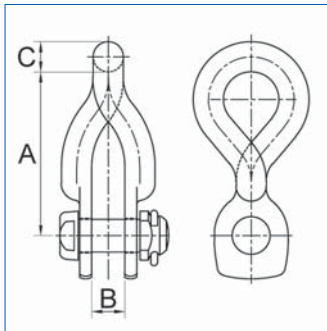

material: steel, hot dip galvanized

L.-Nr.	dimensions in mm			bolt	kN	kg
	A	B	C			
4250.41/1	100	20	20	19	120	0,86
4250.0036	120	24	24	19	240	1,50

Other dimensions are available upon request.

Twin ball pin

according to IEC

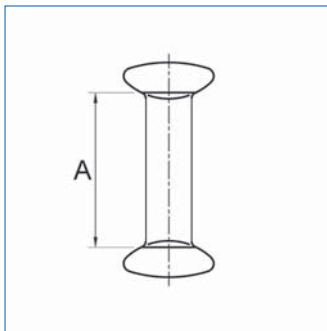

material: steel, forged, hot dip galvanized

L.-Nr.	dimensions in mm	ball eye	kN	kA 1s	kg
	A				
4210.02/1	40	16	130	14	0,20
4210.03/1	49	20	230	22	0,35

Other dimensions are available upon request.

Twin ball pin

according to ÖNORM

material: steel, forged, hot dip galvanized

L.-Nr.	dimensions in mm		ball eye	kN	kA 1s	kg
	A					
4210.02/0	27		16	130	14	0,16

Other dimensions are available upon request.

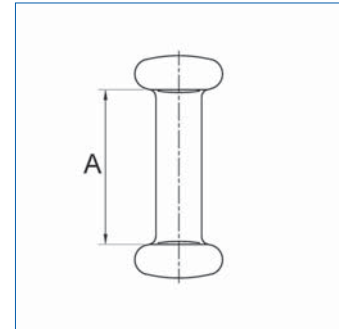

Twin ball pin with arcing device attachment

according to IEC

material: steel, forged, hot dip galvanized

L.-Nr.	dimensions in mm		ball eye	kN	kA 1s	version	kg
	A	B					
4210.10/1	82	19	16	130	40	1	0,33
4210.12/1	138	22	24	320	50	2	1,15

Version 1 has an one-hole arcing device attachment.

Version 2 has a two-hole arcing device attachment, standard hole distance 32 mm for 2 screws M14.

Other hole distances are available upon request.

Models with nozzle upon request.

Other dimensions are available upon request.

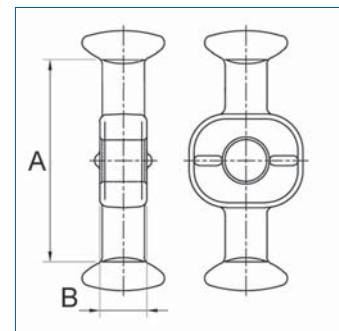
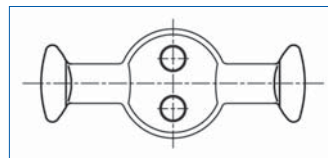
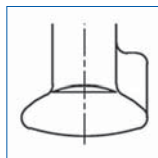

18

Twin ball pin with arcing device attachment according to ÖNORM

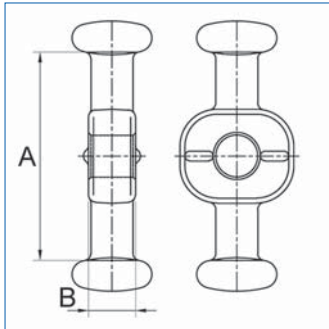

material: steel, forged, hot dip galvanized

L.-Nr.	dimensions in mm		ball eye	kN	kA 1s	kg
	A	B				
4210.10/0	84	19	16	130	40	0,36

Other dimensions are available upon request.

Ball eye

according to IEC

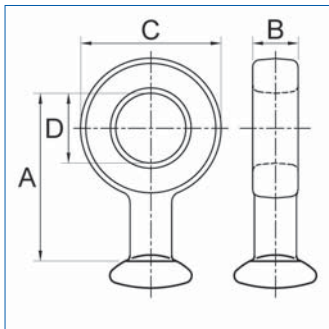

material: steel, forged, hot dip galvanized

L.-Nr.	dimensions in mm				ball eye	kN	kA 1s	kg
	A	B	C	D				
4210.15/1	48	13	40	20	11	60	7	0,12
4210.16/1	62	19	54	24	16	130	14	0,34
4210A16/11	60	19	54	20	16	130	14	0,35
4210.17/3	75	19	55	24	20	210	22	0,47
4210.17/1	80	19	55	30	20	200	22	0,48
4210.17/2/1	75	19	55	20	20	210	22	0,51

Article L.-Nr. **4210.17/1** is also suitable for U-bolts.

Other dimensions are available upon request.

Ball eye

according to ÖNORM

material: steel, forged, hot dip galvanized

L.-Nr.	dimensions in mm				ball eye	kN	kA 1s	kg
	A	B	C	D				
4210.16/2	62	16	56	24	16	130	14	0,34

Other dimensions are available upon request.

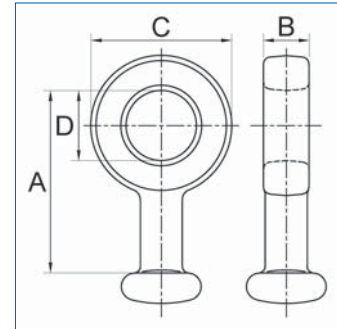

Ball eye long type

according to IEC

material: steel, forged, hot dip galvanized

L.-Nr.	dimensions in mm				ball eye	kN	kA 1s	kg
	A	B	C	D				
4210.20/1	75	13	40	20	11	60	7	0,14
4210.20/2	250	13	40	20	11	60	7	0,29
4210.21/1	76	19	54	24	16	130	14	0,37

Other dimensions are available upon request.

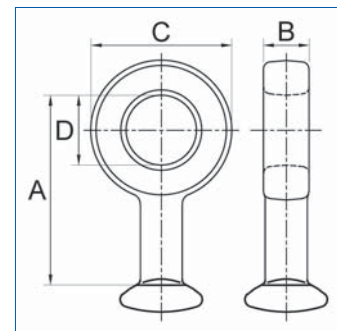

20

Oval ball eye

according to IEC

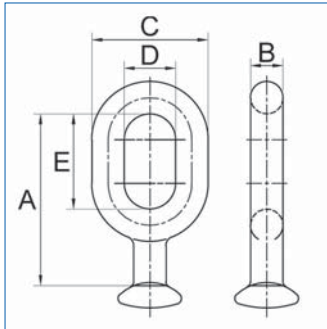

material: steel, forged, hot dip galvanized

L.-Nr.	dimensions in mm					ball eye	kN	kA 1s	kg
	A	B	C	D	E				
4217.13/1	90	18	61	25	50	16	130	14	0,47
4217.12/1	110	19	63	25	60	20	200	22	0,67

Other dimensions are available upon request.

Oval ball eye with collar

according to IEC

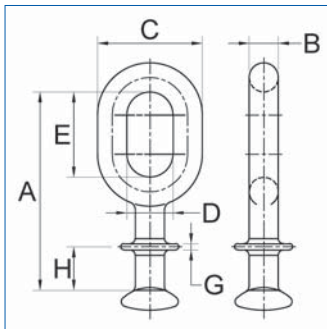

material: steel, forged, hot dip galvanized

L.-Nr.	dimensions in mm								ball eye	kN	kA 1s	kg
	A	B	C	D	E	F	G	H				
4217.0009	150	18	61	25	50	42	5	42	16	130	14	0,90

For hot line maintenance.

Other dimensions are available upon request.

Oval ball eye straight, with arcing device attachment according to IEC

material: steel, forged, hot dip galvanized

L.-Nr.	dimensions in mm					ball eye	kN	kA 1s	version	kg
	A	B	C	D	E					
4213.013/1	104	19	55	26	45	16	130	35	1	0,69
4213.011/1	104	19	55	24	45	16	130	40	1	0,71
4213.012/1	104	19	55	20	45	16	130	40	1	0,72
4213.0015	115	19	62	24	45	16	130	50	3	0,90
4213.023/1	142	19	62	30	56	20	230	40	1	0,85
4213.024/1	125	19	62	27	56	20	230	45	1	0,85
4213.021/1	125	19	62	26	56	20	230	45	1	0,90
4213.02/1	125	19	62	24	56	20	230	50	1	1,01
4213.022/1	125	19	62	20	56	20	230	40	1	1,03
4213.035/1	142	19	70	24	69	24	320	50	2	1,44
4213.032/1	142	22	70	24	69	24	320	50	2	1,62

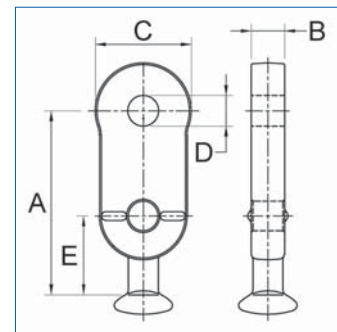

Version 1 has an one-hole arcing device attachment.

Version 2 has a two-hole arcing device attachment, standard hole distance 32 mm for 2 screws M14.

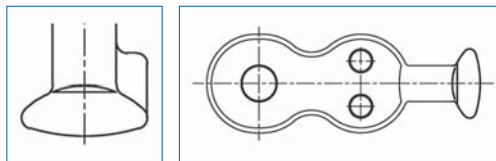

Version 3 has a two-hole arcing device attachment, standard hole distance 32 mm for 2 screws M12.

Other hole distances are available upon request.

Models with nozzle upon request.

Other dimensions are available upon request.

22

Oval ball eye straight, with arcing device attachment according to ÖNORM

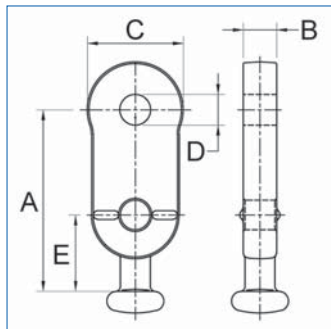

material: steel, forged, hot dip galvanized

L.-Nr.	dimensions in mm					ball eye	kN	kA 1s	version	kg
	A	B	C	D	E					
4213.013/0	104	19	55	26	48	16	130	35	1	0,65
4213.011/0	104	19	55	24	48	16	130	40	1	0,69
4213.012/0	104	19	55	20	48	16	130	40	1	0,71
4213.02/0	129	19	60	24	57	20	230	45	1	0,95
4213.022/0	129	19	60	20	57	20	230	40	1	0,95

Models with nozzle upon request.

Other dimensions are available upon request.

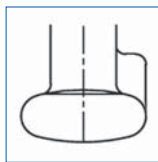

Oval ball eye straight, with arcing device attachment, long type according to IEC

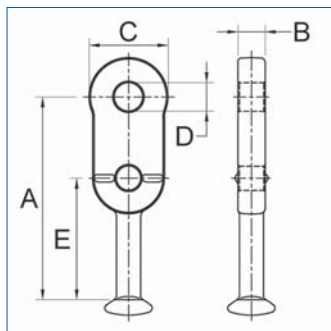

material: steel, forged, hot dip galvanized

L.-Nr.	dimensions in mm					ball eye	kN	kA 1s	kg
	A	B	C	D	E				
4215.011/1	142	19	55	24	85	16	130	40	0,80
4215.012/1	142	19	55	20	85	16	130	40	0,80
4215.022/1	175	19	60	20	104	20	230	40	0,90
4215.021/1	175	19	60	24	104	20	230	45	1,07

Models with nozzle upon request.

Other dimensions are available upon request.

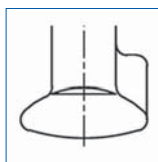

Oval ball eye straight, with arcing device attachment, long type
 according to ÖNORM

material: steel, forged, hot dip galvanized

L.-Nr.	dimensions in mm					ball eye	kN	kA 1 s	kg
	A	B	C	D	E				
4215.01/0	142	19	55	30	85	16	130	30	0,68
4215.011/0	142	19	55	24	85	16	130	40	0,73
4215.012/0	142	19	55	20	85	16	130	40	0,79

Article L.-Nr. **4215.01/0** is also suitable for U-bolts.

Other dimensions are available upon request.

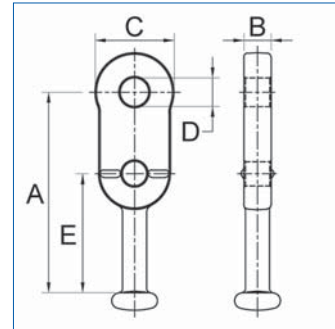

Oval ball eye straight, with arcing device attachment
 according to IEC

material: steel, forged, hot dip galvanized

L.-Nr.	dimensions in mm						ball eye	kN	kA 1 s	kg
	A	B	C	D	E	F				
4217.50/1	132	16	57	25	50	48	16	130	25	0,63
4217.51/1	150	19	63	25	60	56	20	230	40	0,93
4217.51/2	164	19	68	40	60	56	20	185	40	1,10

Other dimensions are available upon request.

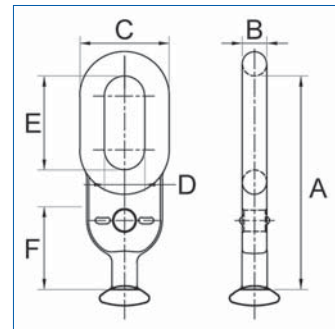

24

Ball eye twisted, with arcing device attachment according to IEC

material: steel, forged, hot dip galvanized

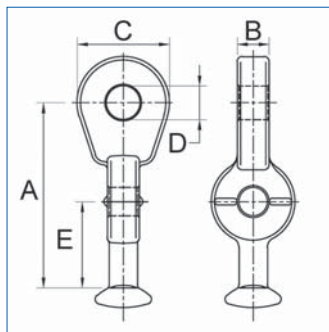

L.-Nr.	dimensions in mm					ball eye	kN	kA 1s	version	kg
	A	B	C	D	E					
4213.09/0	70	13	40	20	32	11	60	12	1	0,20
4213.101/1	104	19	55	24	45	16	130	40	1	0,62
4213.102/1	104	19	55	20	45	16	130	40	1	0,63
4213.103/1	104	19	55	26	45	16	130	35	1	0,64
4213.101/2	130	19	62	24	50	16	130	50	3	1,00
4213.112/1	125	19	62	26	56	20	230	45	1	0,88
4213.111/2/S	130	19	62	24	58	20	230	50	2	0,90
4213.111/1	125	19	62	24	56	20	230	50	1	0,97
4213.113/1	125	19	62	20	56	20	230	40	1	0,97
4213.124	145	19	70	24	65	24	320	50	1	1,43
4213.124/1	168	19	70	24	68	24	320	50	2	1,70

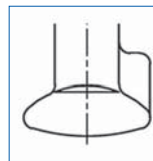
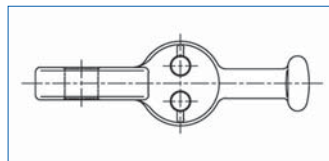

Version 1 has an one-hole arcing device attachment.

Version 2 has a two-hole arcing device attachment, standard hole distance 32 mm for 2 screws M14.

Version 3 has a two-hole arcing device attachment, standard hole distance 32 mm for 2 screws M12.

Other hole distances are available upon request.

Models with nozzle upon request.

Other dimensions are available upon request.

Ball eye twisted, with arcing device attachment
 according to ÖNORM

material: steel, forged, hot dip galvanized

L.-Nr.	dimensions in mm					ball eye	kN	kA 1s	version	kg
	A	B	C	D	E					
4213.103/0	110	19	55	26	48	16	130	35	1	0,64
4213.101/0	110	19	55	24	48	16	130	35	1	0,68
4213.102/0	110	19	55	20	48	16	130	40	1	0,69
4213.111/0	127	19	62	24	56	20	230	40	1	0,98
4213.113/0	127	19	62	20	56	20	230	40	1	0,98

Models with nozzle upon request.

Other dimensions are available upon request.

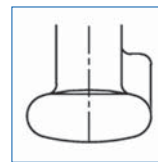
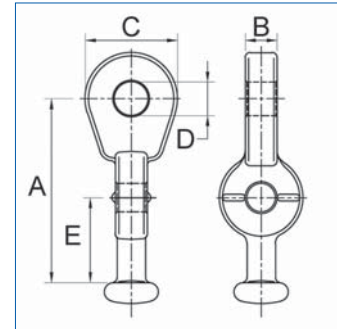

Ball eye twisted, with arcing device attachment, long type
 according to IEC

material: steel, forged, hot dip galvanized

L.-Nr.	dimensions in mm					ball eye	kN	kA 1s	kg
	A	B	C	D	E				
4215.102/1	147	19	55	20	85	16	130	40	0,80
4215.111/1	175	19	63	24	104	20	230	40	1,08

Other dimensions are available upon request.

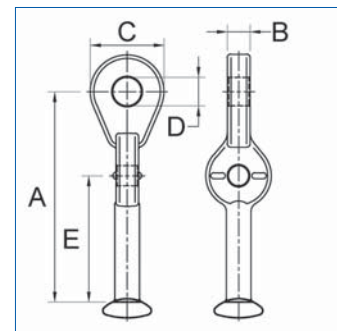

26

Ball eye twisted, with arcing device attachment, long type
according to ÖNORM

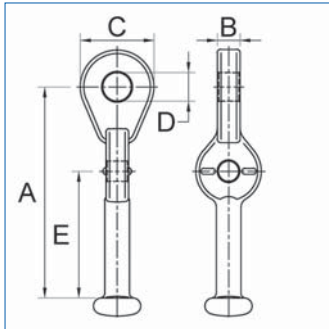

material: steel, forged, hot dip galvanized

L.-Nr.	dimensions in mm						ball eye	kN	kA 1s	kg
	A	B	C	D1	D2	E				
4215.102/0	147	19	55	20	17	85	16	130	30	0,72

Other dimensions are available upon request.

Oval ball eye twisted, with arcing device attachment
according to IEC

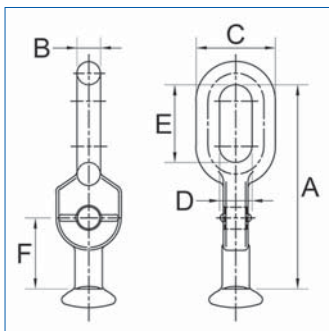

material: steel, forged, hot dip galvanized

L.-Nr.	dimensions in mm						ball eye	kN	kA 1s	kg
	A	B	C	D	E	F				
4217.40/1	132	16	57	25	50	48	16	130	25	0,59
4217.41/1	160	18	61	25	60	57	20	230	35	0,93

Other dimensions are available upon request.

Ball clevis

according to IEC

material: steel, forged, hot dip galvanized

L.-Nr.	dimensions in mm			ball eye	bolt	kN	kA 1s	kg
	A	B	C					
4217.20/1	65	20	38	16	16	130	14	0,50
4217.23/1	65	20	38	16	19	130	14	0,52
4217.27/1	85	24	50	20	19	230	22	0,71
4217.0030	95	24	95	24	19	240	32	1,20

Other dimensions are available upon request.

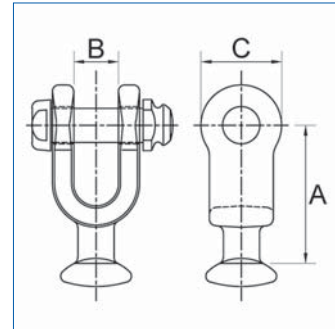

Ball clevis with arcing device attachment, straight

according to IEC

material: steel, forged, hot dip galvanized

L.-Nr.	dimensions in mm				ball eye	bolt	kN	kA 1s	kg
	A	B	C	E					
4217.30/1	115	20	50	45	16	19	130	30	1,08
4217.29/1	135	20	50	56	20	19	230	40	1,38

Other dimensions are available upon request.

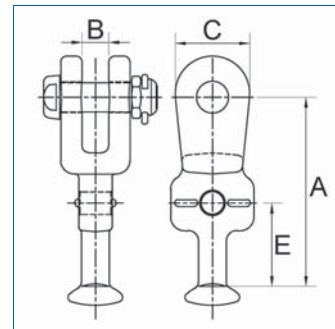

28

Ball clevis with arcing device attachment, twisted according to IEC

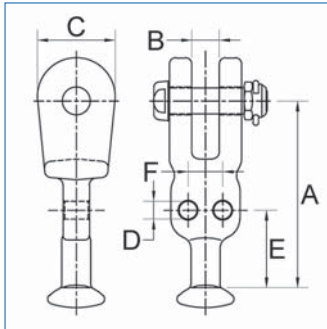

material: steel, forged, hot dip galvanized

L.-Nr.	dimensions in mm				ball eye	bolt	kN	kA 1s	kg
	A	B	C	E					
4217.0024	125	23	56	45	16	19	130	40	1,55
4217.32/1	125	23	56	45	16	22	130	50	1,62
4217.33/1	135	23	56	55	20	22	230	50	1,70
4217.0045	150	24	56	69	24	22	320	50	2,32

The arcing device attachment has a standard hole distance of 32 mm for 2 screws M12.

Other hole distances are available upon request.

Other dimensions are available upon request.



Socket eye casted according to IEC

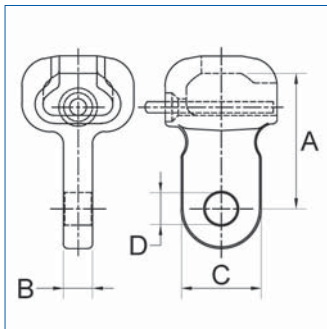

material: malleable or ductile iron, hot dip galvanized

L.-Nr.	dimensions in mm				ball eye	kN	kA 1s	kg
	A	B	C	D				
4220.08/1	71	19	50	20	16	130	14	0,87
4220.11/2	75	19	62	20	20	210	40	1,33

Other dimensions are available upon request.



Socket eye forged

according to IEC

material: steel, forged, hot dip galvanized

L.-Nr.	dimensions in mm				ball eye	kN	kA 1s	kg
	A	B	C	D				
4220.02/1	71	19	45	20	16	130	14	0,69
4220.021/1	71	19	45	18	16	130	14	0,72
4220.11/1	85	19	55	20	20	230	22	1,22
4220.111/1	85	19	55	24	20	230	22	1,20

Other dimensions are available upon request.

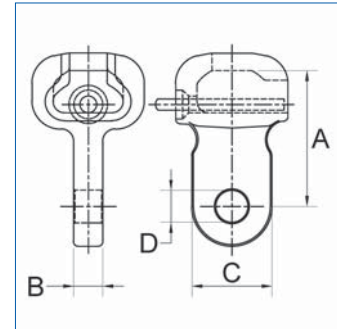

Socket tongue casted, straight, with arcing horn attachment

according to IEC

material: malleable or ductile iron, hot dip galvanized

L.-Nr.	dimensions in mm					ball eye	kN	kA 1s	version	kg
	A	B	C	D	E					
4220.206/1	106	19	50	20	51	16	130	30	1	0,97
4220.216/1	135	19	62	20	66	20	210	40	1	1,78

Other dimensions are available upon request.

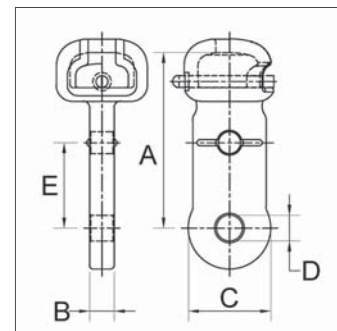

30

Socket tongue forged, straight, with arcing horn attachment according to IEC

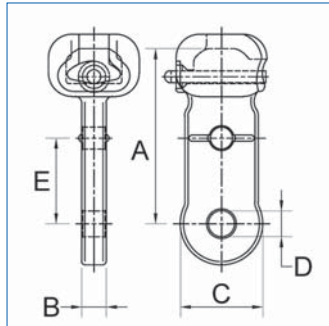

material: steel, forged, hot dip galvanized

L.-Nr.	dimensions in mm					ball eye	kN	kA 1s	version	kg
	A	B	C	D	E					
4220.20/1	120	19	56	20	63	16	130	40	1	1,07
4220.201/1	120	19	56	24	63	16	130	40	1	1,06
4220.21/1	135	19	62	24	66	20	230	50	1	1,61
4220.211/1	135	19	62	20	66	20	230	40	1	1,63
4220.23/1	161	22	70	27	73	24	320	50	2	2,97
4220.26/1	161	19	70	24	73	24	300	50	2	2,95
4220.53/3	220	24	80	34	115	32	550	50	2	6,50

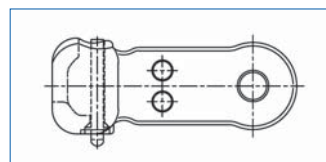

Version 1 has an one-hole arcing device attachment.
Version 2 has a two-hole arcing

device attachment, standard hole distance 32 mm for 2 screws M14.
Other hole distances are available upon request.
Other dimensions are available upon request.

Socket tongue forged, straight, with arcing horn attachment according to ÖNORM

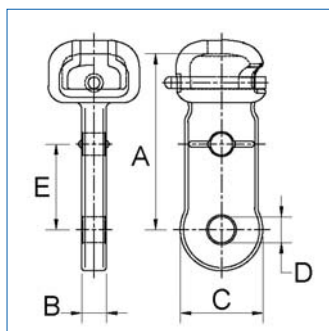

material: steel, forged, hot dip galvanized

L.-Nr.	dimensions in mm					ball eye	kN	kA 1s	version	kg
	A	B	C	D	E					
4220.20/0	120	19	56	20	63	16	130	40	1	1,00

Other dimensions are available upon request.



Socket tongue casted, with arcing device attachment, twisted according to IEC

material: malleable or ductile iron, hot dip galvanised

L.-Nr.	dimensions in mm					ball eye	kN	kA 1s	version	kg
	A	B	C	D	E					
4220.301/2	128	19	50	20	71	16	130	30	1	1,15
4220.301/4	130	19	64	24	75	16	160	50	3	1,40
4220.301/5	135	19	64	20	80	16	160	40	3	1,40
4220.316/1	145	19	62	20	76	20	210	40	1	1,78

Version 1 has an one-hole arcing device attachment.

Version 3 has a two-hole arcing device attachment, standard hole distance 32 mm for 2 screws M12.

Other hole distances are available upon request.

Other dimensions are available upon request.

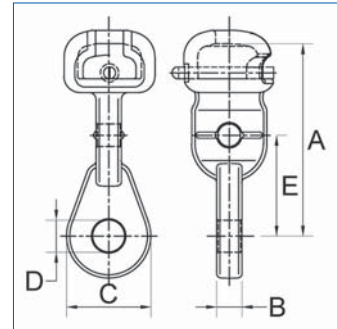
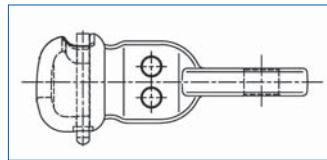

Socket tongue forged, with arcing device attachment, twisted according to IEC

material: steel, forged, hot dip galvanized

L.-Nr.	dimensions in mm						ball eye	kN	kA 1s	version	kg
	A	B	C	D1	D2	E					
4220.30/1	128	19	56	24	17	71	16	130	40	1	1,11
4220.301/1	128	19	56	20	17	71	16	130	40	1	1,11
4220.31/1	145	19	62	24	17	76	20	230	50	1	1,66
4220.311/1	145	19	62	20	17	76	20	230	40	1	1,71
4220.36	162	19	70	24	17	87	24	320	50	1	2,83
4220.36/1	188	19	70	24	15	100	24	320	50	2	3,03

Version 1 has an one-hole arcing device attachment.

Version 2 has a two-hole arcing device attachment, standard hole distance 32 mm for 2 screws M14.

Other hole distances are available upon request.

Other dimensions are available upon request.

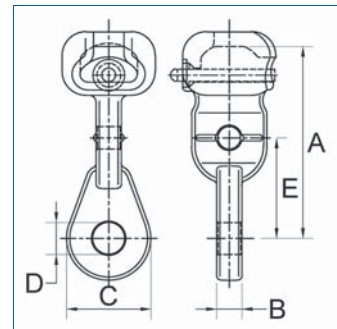
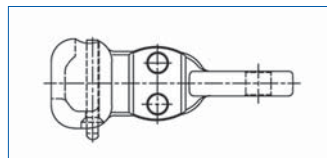

32

Socket tongue forged, with arcing device attachment, twisted according to ÖNORM

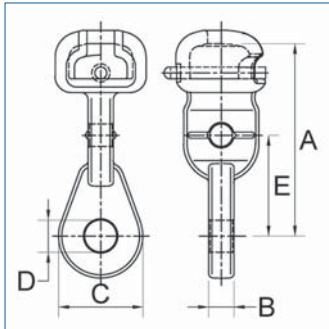

material: steel, forged, hot dip galvanized

L.-Nr.	dimensions in mm					ball eye	kN	kA 1s	version	kg
	A	B	C	D	E					
4220.30/0	128	19	55	20	71	16	130	30	1	1,02
4220.311/0	145	19	62	20	76	20	230	40	1	1,50

Other dimensions are available upon request.

Socket clevis casted according to IEC

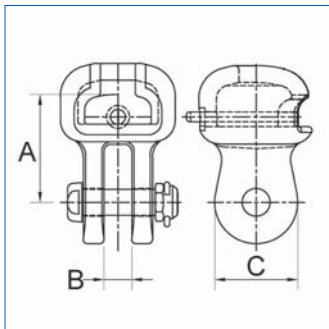

material: malleable or ductile iron, hot dip galvanised

L.-Nr.	dimensions in mm			ball eye	bolt	kN	kA 1s	kg
	A	B	C					
4225.13/2	60	20	50	16	19	130	14	1,04
4225.140/1	80	20	60	20	19	230	22	1,92
4225.40	100	20	70	24	22	300	32	3,12

Other dimensions are available upon request.

Socket clevis forged

according to IEC

material: steel, forged, hot dip galvanized

L.-Nr.	dimensions in mm			ball eye	bolt	kN	kA 1s	kg
	A	B	C					
4225.13/3	65	20	50	16	19	130	14	1,20
4225.140/2	80	20	56	20	19	210	22	1,50

Other dimensions are available upon request.

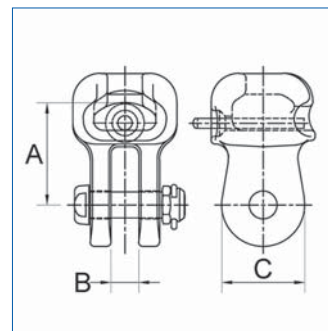

Socket clevis casted, with arcing device attachment, twisted

according to IEC

material: malleable or ductile iron, hot dip galvanised

L.-Nr.	dimensions in mm				ball eye	bolt	kN	kA 1s	version	kg
	A	B	C	E						
4225.15/1	135	20	60	60	20	19	210	40	1	2,30

Other dimensions are available upon request.

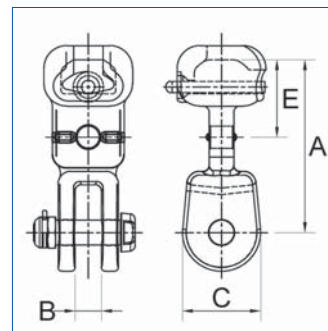

34

Double eye straight

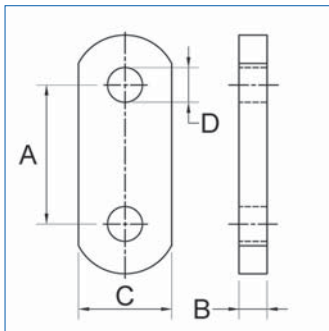

material: steel, hot dip galvanized

L.-Nr.	dimensions in mm				kN	kA 1s	kg
	A	B	C	D			
4260.01	50	13	40	22	60	10	0,29
4260.04	70	19	50	20	240	35	0,77
4260.05/9	75	19	60	24	300	45	1,04
4260.05/7	80	19	60	20	240	40	1,03
4260.04/1	100	19	50	20	240	35	0,97
4260.22/2	100	24	80	30	480	70	2,40
4260.15	150	19	60	24	300	45	1,70
4260.04/14	200	19	50	20	240	35	1,69
4260.05/13	200	19	60	20	240	40	2,10
4260.01/9	300	19	50	20	240	35	2,39
4260.16	300	19	60	24	300	45	2,95

Other dimensions are available upon request.

Double eye twisted, forged

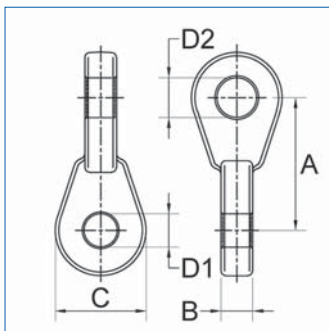

material: steel, forged, hot dip galvanized

L.-Nr.	dimensions in mm					kN	kA 1s	kg
	A	B	C	D1	D2			
4261.08/10	70	19	50	20	20	200	30	0,63
4261.08	80	19	55	20	20	200	40	0,78
4261.10/1	90	19	60	20	24	240	40	0,89
4261.11	90	19	60	24	24	280	40	0,88
4261.12	100	19	65	24	24	320	50	1,17
4261.12/1	100	19	65	27	27	340	50	0,95
4261.17	110	22	70	30	30	420	50	1,55
4261.0047	140	20	90	34	34	600	70	3,20
4261.18	140	24	80	34	34	640	70	3,20

Other dimensions are available upon request.



Double eye twisted, flat steel

material: steel, hot dip galvanized

L.-Nr.	dimensions in mm					kN	kA 1s	kg
	A	B	C	D1	D2			
4261.65/2	120	19	50	20	20	240	35	1,10
4261.65/4	150	19	50	20	20	240	35	1,30
4261.71/3	150	19	60	24	24	320	45	2,00
4261.65/6	200	19	50	20	20	240	35	1,80
4261.66/3	200	19	50	20	20	160	35	1,80
4261.66/4	200	19	50	24	24	160	32	1,70
4261.41	210	20	70	30	30	500	50	2,92
4261.46/1	250	19	60	20	20	260	40	2,60
4261.71/2	250	19	60	24	24	320	45	2,80
4261.67/1	250	24	90	34	34	630	50	6,10
4261.0010	300	19	60	24	24	320	45	3,15

Other dimensions are available upon request.

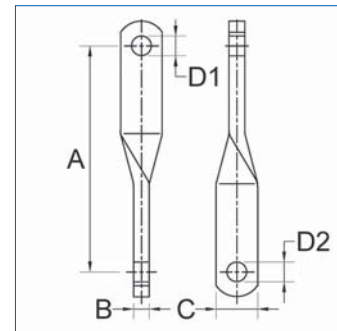

Oval double eye twisted, flat steel

material: steel, hot dip galvanized

L.-Nr.	dimensions in mm						kN	kA 1s	kg
	A	B	C	D1	D2	E			
4261.45/1	125	19	50	20	28	50	240	30	1,00
4261.45	125	19	50	24	28	50	240	30	0,97
4261.44/2	150	15	50	20	22	45	200	28	1,00
4261.64/1	215	25	80	30	38	90	480	70	4,70
4261.67/3	215	24	90	34	38	90	640	70	5,60

Other dimensions are available upon request.

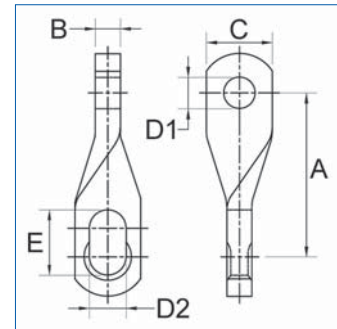

36

Double eye with arcing device attachment, straight

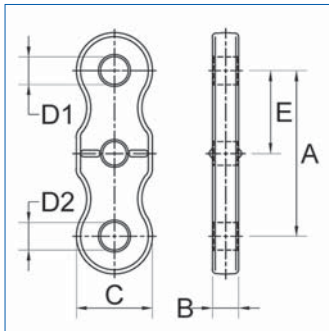

material: steel, forged, hot dip galvanized

L.-Nr.	dimensions in mm						kN	kA 1s	kg
	A	B	C	D1	D2	E			
4261.50	106	19	50	20	20	53	240	40	0,82
4261.51/10	120	19	55	20	20	60	240	40	1,04
4261.51/10/1	120	19	55	20	24	60	240	40	1,00
4261.51/0	120	19	60	24	24	60	300	45	1,04
4261.52/3	132	19	65	20	24	66	240	50	1,29
4261.52	132	19	65	24	24	66	320	50	1,30
4261.52/1	132	19	65	24	27	66	320	50	1,41

Articles with an anti rotation protection are available upon request.

Other dimensions are available upon request.



Double eye with arcing device attachment, twisted

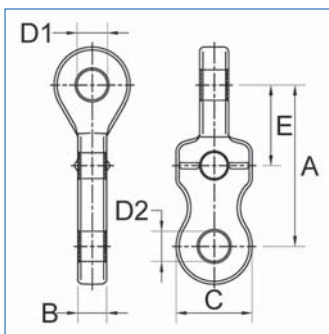

material: steel, forged, hot dip galvanized

L.-Nr.	dimensions in mm						kN	kA 1s	kg
	A	B	C	D1	D2	E			
4261.30	106	19	50	20	20	53	200	30	0,79
4261.31/10	120	19	55	20	20	60	240	40	1,06
4261.31/10/1	120	19	55	20	24	60	240	40	1,04
4261.31/0	120	19	60	24	24	60	300	40	1,09
4261.34/4	132	19	65	24	20	66	240	50	1,27
4261.34/1	132	19	65	24	24	66	320	50	1,26
4261.34/3	132	24	65	24	27	66	320	50	1,39
4261.34/10	132	24	65	27	27	66	320	50	1,40
4261.34/20	144	24	65	27	27	72	380	63	1,90

Articles with an anti rotation protection are available upon request.

Other dimensions are available upon request.



Double eye straight, with arcing device attachment, connection twisted

material: steel, forged, hot dip galvanized

L.-Nr.	dimensions in mm						kN	kA 1s	kg
	A	B	C	D1	D2	E			
4261.40/1	106	19	50	20	20	53	200	30	0,79
4261.40/3	120	19	55	20	20	60	240	40	1,02
4261.40/2	120	19	60	24	24	60	300	40	1,07
4261.40/4	132	19	65	24	24	66	320	50	1,29

Articles with an anti rotation protection are available upon request.

Other dimensions are available upon request.

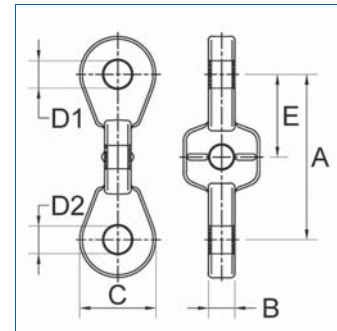

Oval double eye with arcing device attachment, straight

material: steel, forged, hot dip galvanized

L.-Nr.	dimensions in mm							kN	kA 1s	kg
	A	B	C	D1	D2	E	F			
4261.57/1	140	19	50	20	25	50	53	130	25	0,91

Other dimensions are available upon request.

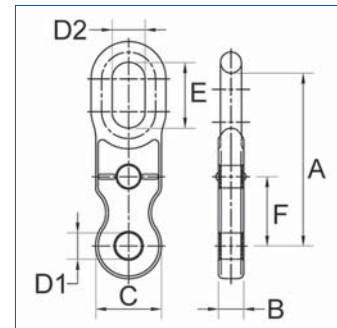

Oval double eye straight, with arcing device attachment, connection twisted

material: steel, forged, hot dip galvanized

L.-Nr.	dimensions in mm							kN	kA 1s	kg
	A	B	C	D1	D2	E	F			
4261.56/1	140	19	50	20	25	50	53	130	25	0,84

Other dimensions are available upon request.

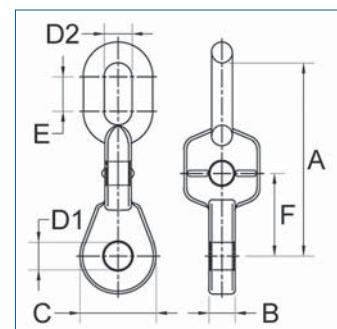

38

Oval double eye with arcing device attachment, twisted

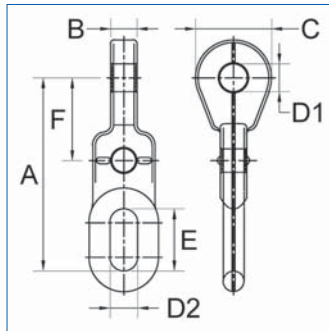

material: steel, forged, hot dip galvanized

L.-Nr.	dimensions in mm							kN	kA 1s	kg
	A	B	C	D1	D2	E	F			
4261.55/1	140	19	50	20	25	50	53	130	25	0,90

Other dimensions are available upon request.

Double straps

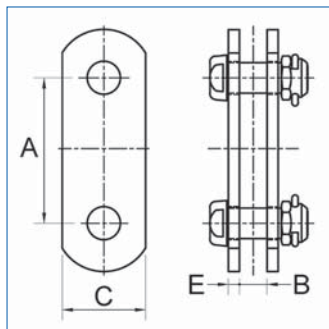

material: steel, hot dip galvanized

L.-Nr.	dimensions in mm				bolt 1	bolt 2	kN	kA 1s	kg
	A	B	C	E					
4263.10	70	20	40	6	19	19	75	15	0,66
4263.11/1	70	20	40	8	19	19	100	20	0,82
4263.12	70	20	50	8	19	19	200	32	1,00
4263.38	70	20	60	8	19	19	210	40	1,23
4263.17/1	80	20	60	10	22	22	320	50	1,64
4263.17	80	24	60	10	22	22	320	50	1,73
4263.10/1	90	20	40	6	19	19	75	15	0,79
4263.12/1	90	20	50	8	19	19	200	32	1,17
4263.38/5	100	20	60	8	19	19	210	40	1,40
4263.32	100	20	60	8	22	22	280	40	1,61
4263.31	100	20	70	10	28	28	420	50	2,60
4263.31/1	100	26	70	10	28	28	420	50	2,70
4263.37/4	105	24	80	12	28	28	460	63	3,55
4263.12/19	150	20	50	8	19	19	200	32	1,80
4263.11	200	20	40	8	19	19	100	20	1,50



Welded models are available upon request.

Other dimensions are available upon request.

Clevis eye straight

material: steel, hot dip galvanized

L.-Nr.	dimensions in mm					bolt	kN	kA 1s	kg
	A	B	C	D	E				
4265.01	75	20	40	20	12	19	75	15	0,52
4265.01/1	100	20	40	20	12	19	75	15	0,65
4265.02/1	100	20	40	20	19	19	100	20	0,92
4265.03/1/0	100	20	50	20	19	19	160	32	1,16
4265.04/30	100	20	60	20	19	19	240	40	1,30
4265.04/33/30	100	20	60	20	19	19	240	40	1,30
4265.04/66/2	100	20	70	24	16	22	320	50	1,70
4265.04/200	100	24	60	24	19	22	280	40	2,60
4265.04/33/14	125	20	60	20	19	19	240	40	1,45
4265.07/18	125	24	70	27	20	25	310	63	2,50
4265.09/11	125	26	70	30	24	28	410	50	3,30
4265.01/3	150	20	40	20	12	19	75	15	0,90
4265.02/3	150	20	40	20	19	19	100	20	1,07
4265.03/3/0	150	20	50	20	19	19	160	32	1,45
4265.04/31	150	20	60	20	19	19	240	40	1,60
4265.04/66/16	150	20	70	24	16	22	320	50	1,90
4265.04/202	150	24	60	24	19	22	280	40	2,60
4265.07/20	150	24	70	27	20	25	310	63	2,70
4265.09/12	150	26	70	30	24	28	410	50	3,20
4265.02/6	200	20	40	20	19	19	100	20	1,30
4265.03/31/6	200	20	50	20	19	19	160	32	1,75
4265.04/32	200	20	60	20	19	19	240	40	2,00
4265.04/66/1	200	20	70	24	16	22	320	50	2,60
4265.07/28	200	24	70	27	20	25	310	63	3,20
4265.03/31/0	250	20	50	20	19	19	160	32	1,96
4265.04/204	250	24	60	24	19	22	280	40	2,60
4265.07/22	250	24	70	27	20	25	310	63	3,70
4265.09/13	250	26	70	30	24	28	410	50	4,90
4265.02/8	300	20	40	20	19	19	100	20	1,84
4265.04/33/4	300	20	60	20	19	19	240	40	2,90
4265.04/33/11	400	20	60	20	19	19	240	40	3,56
4265.02/17	500	20	40	20	19	19	100	20	2,50
4265.04/35	500	20	60	20	19	19	240	40	4,30
4265.04/66/9	500	20	70	24	16	22	320	50	4,50
4265.09/15	500	26	70	30	24	28	410	50	8,20

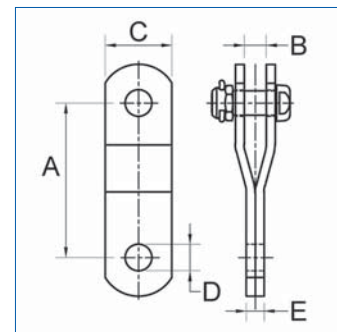

The delivery of clevis eyes with a different orientation is possible upon request.

Other dimensions are available upon request.

Clevis eye straight, riveted

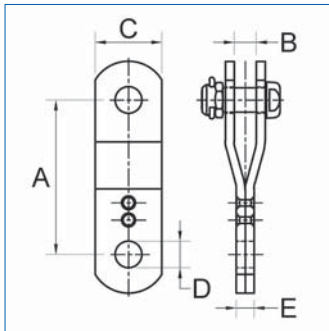

material: steel, hot dip galvanized

L.-Nr.	dimensions in mm					bolt	kN	kA 1 s	kg
	A	B	C	D	E				
4265.01/9/20	75	20	40	22	13	13	55	14	0,50
4265.9002	100	20	50	20	19	19	200	32	1,10
4265.9022	100	20	60	24	19	22	280	40	1,30
4265.04/660	100	20	70	24	19	22	320	50	1,57
4265.07/51	100	26	70	27	24	25	380	50	1,50
4265.9036	150	20	60	24	19	22	280	40	1,70
4265.07/53	150	26	70	27	24	25	380	50	2,30
4265.9012	200	20	50	20	19	19	200	32	1,80
4265.9025	200	20	60	24	19	22	280	40	2,10
4265.04/663	200	20	70	24	19	22	320	50	2,30
4265.07/55	200	26	70	27	24	25	380	50	3,10
4265.9030	250	20	50	20	19	19	200	32	2,10
4265.9026	250	20	60	24	19	22	280	40	2,30
4265.9014	300	20	50	20	19	19	200	32	2,30
4265.9028	300	20	60	24	19	22	280	40	2,60
4265.04/665	300	20	70	24	19	22	320	50	3,33
4265.07/57	400	26	70	27	24	25	380	50	5,30

The delivery of clevis eyes with a different orientation is possible upon request.

Other dimensions are available upon request.

Clevis eye straight, welded

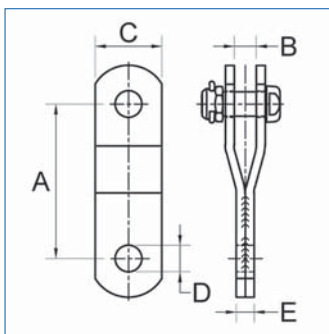

material: steel, hot dip galvanized

L.-Nr.	dimensions in mm					bolt	kN	kA 1 s	kg
	A	B	C	D	E				
4265.01/9/31/1	100	14	40	14	13	13	55	13	0,60
4265.501	100	20	50	20	19	19	200	32	1,10
4265.04/41	100	20	60	20	19	19	240	40	1,28
4265.04/61	100	20	70	24	19	22	280	50	1,70
4265.502	125	20	50	20	19	19	200	32	1,32
4265.04/62	125	20	70	24	19	22	280	50	1,62
4265.503	150	20	50	20	19	19	200	32	1,42
4265.04/42	150	20	60	20	19	19	240	40	1,49
4265.04/43	150	20	60	20	19	19	240	40	1,65
4265.04/63	150	20	70	24	19	22	280	50	1,80
4265.508	200	20	50	20	19	19	200	32	1,70
4265.04/47	200	20	60	20	19	19	240	40	2,01
4265.04/66	200	20	70	24	19	22	280	50	2,49
4265.504	250	20	50	20	19	19	200	32	2,05
4265.04/47/2	250	20	60	20	19	19	240	40	2,41
4265.04/67	250	20	70	24	19	22	280	50	3,00

3

STRING HARDWARE



41

material: steel, hot dip galvanized

L.-Nr.	dimensions in mm					bolt	kN	kA 1s	kg
	A	B	C	D	E				
4265.505	300	20	50	20	19	19	200	32	2,41
4265.04/44	300	20	60	20	19	19	240	40	2,80
4265.04/5	300	20	70	24	19	22	280	50	3,40

The delivery of clevis eyes with a different orientation is possible upon request.

Other dimensions are available upon request.

Clevis eye twisted, forged

material: steel, forged, hot dip galvanized

L.-Nr.	dimensions in mm				bolt	kN	kA 1s	kg
	A	B	C	D				
4265.74/10	90	20	16	18	16	120	25	0,70
4265.73	90	20	19	20	19	240	32	1,10
4265.76/6	100	20	19	20	19	200	40	1,66
4265.76/8	100	26	19	20	19	210	40	1,71
4265.0012	100	26	19	20	22	240	40	1,50
4265.76/1	100	20	19	24	22	320	40	1,69
4265.76/20	100	26	19	24	22	320	50	1,80

Other dimensions are available upon request.

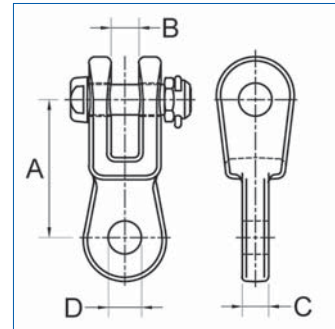

42

Clevis eye with arcing device attachment, straight, forged

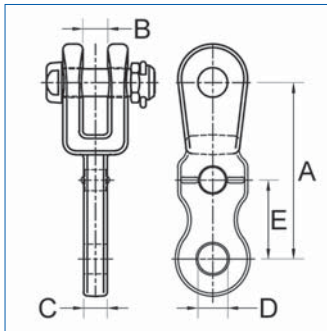

material: steel, forged, hot dip galvanized

L.-Nr.	dimensions in mm				bolt	kN	kA 1s	kg
	A	B	C	D				
4265.0086	145	20	19	20	22	240	50	2,00

Other dimensions are available upon request.

Clevis eye with arcing device attachment, twisted, forged

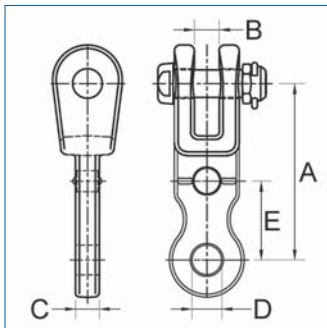

material: steel, forged, hot dip galvanized

L.-Nr.	dimensions in mm				bolt	kN	kA 1s	kg
	A	B	C	D				
4265.0087	145	20	19	24	22	320	50	1,90
4265.0100	145	20	24	27	22	330	50	2,10

Other dimensions are available upon request.

Adjustable extension link straight

material: steel, hot dip galvanized

L.-Nr.	dimensions in mm				bolt	kN	kA 1 s	kg
	A	B	C	D				
4266.10/3	235 - 340	20	19	20	19	160	32	2,94
4266.09	246 - 346	20	19	24	22	320	44	4,17
4266.30	265 - 405	20	19	20	19	160	32	3,17
4266.30/2	265 - 405	20	19	24	19	160	32	3,32
4266.59	290 - 430	20	19	20	19	240	40	4,20
4266.09/1	300 - 450	20	19	24	22	300	44	4,98
4266.53	309 - 441	20	19	24	22	230	40	4,50
4266.53/3	310 - 490	20	19	20	19	240	40	4,45
4266.09/2	470 - 790	20	19	24	22	320	45	7,30
4266.34/1	490 - 840	20	19	20	19	160	32	5,82
4266.51/4	550 - 770	20	19	20	19	240	40	6,80
4266.51/9	550 - 770	20	19	22	19	240	40	6,70
4266.51/8	550 - 770	20	19	24	19	240	40	6,70
4266.51/1	550 - 770	20	19	24	22	230	40	6,70
4266.51/7	550 - 770	20	19	26	22	230	40	6,70
4266.51	550 - 770	20	19	28	22	230	40	6,74
4266.51/3	550 - 770	20	19	29	19	240	40	6,80
4266.51/5	550 - 770	20	19	32	19	240	40	6,80

Other dimensions are available upon request.

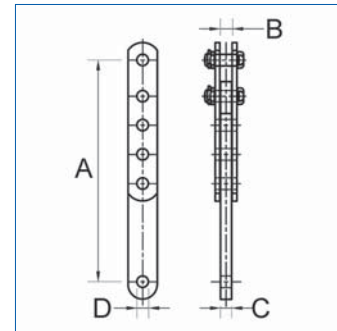

Adjustable extension link twisted

material: steel, hot dip galvanized

L.-Nr.	dimensions in mm				bolt	kN	kA 1 s	kg
	A	B	C	D				
4267.31/3	350 - 500	20	19	20	19	200	32	3,96
4267.31	350 - 500	20	19	21	19	160	32	3,96
4267.313	350 - 500	20	19	24	19	160	32	3,93
4267.312	350 - 500	20	19	25	19	160	32	3,94
4267.314	350 - 500	20	19	27	19	120	28	3,94
4267.62/1	410 - 555	20	19	24	22	230	40	5,32
4267.62	410 - 555	20	19	26	22	230	40	5,40
4267.33/2	480 - 720	20	19	20	19	160	32	5,26
4267.35/1	550 - 770	20	19	20	19	160	32	5,76
4267.50/1	550 - 770	20	19	24	22	230	40	6,80
4267.50/4	550 - 770	20	19	26	22	230	40	6,78
4267.35	550 - 770	20	19	29	19	120	25	5,70
4267.50	550 - 770	20	19	29	22	230	40	6,85

Other dimensions are available upon request.

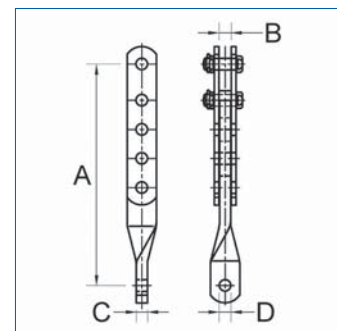

44

Sag adjuster

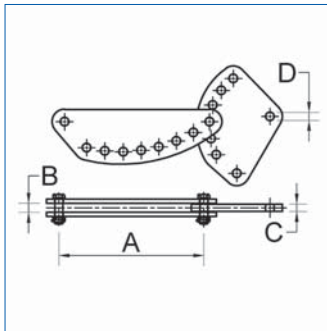

material: steel, hot dip galvanized

L.-Nr.	dimensions in mm				bolt	kN	kA 1s	kg
	A	B	C	D				
4266.61/6/1	209 - 508	20	19	20	19	160	40	10,00
4266.61/5	209 - 508	20	19	20	19	210	40	12,40
4266.61/3	209 - 508	20	19	24	22	210	40	12,10
4266.61/4	209 - 508	24	19	24	22	320	50	12,40

These sag adjusters enable balanced re-adjustment.

Other dimensions are available upon request.

Turnbuckle eye-eye

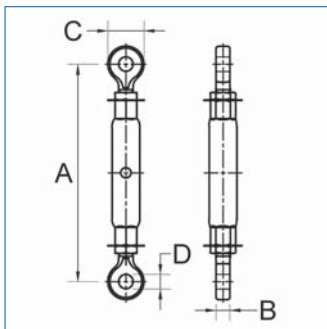

material: steel, forged, hot dip galvanized

L.-Nr.	dimensions in mm				thread	kN	kA 1s	kg
	A	B	C	D				
4268.32	300 - 420	19	50	20	M20	160	18	1,91
4268.51/R	370 - 550	19	50	20	M20	180	15	2,43
4268.53/R	600 - 800	19	50	50	M20	180	15	3,37
4268.02/10	380 - 505	19	55	20	M24	240	25	2,98
4268.02	380 - 505	19	55	24	M24	240	25	2,95
4268.02/2	560 - 810	19	55	20	M24	240	25	4,55
4268.03/1	410 - 545	19	60	20	M27	240	35	4,26
4268.03	410 - 545	19	60	24	M27	280	35	4,55
4268.03/3	540 - 790	19	60	24	M27	280	35	5,80
4268.50	460 - 630	19	60	20	TR30	240	40	4,99
4268.50/1	460 - 630	19	60	24	TR30	320	40	4,93

The screws of the turnbuckles are locked by security split pins. To show the full (maximum) extent of the screw length coloured marking is visible. Turnbuckles must not be subjected to a bending load.

Other types are available upon request.

Turnbuckle eye-clevis

material: steel, forged, hot dip galvanized

L.-Nr.	dimensions in mm				thread	bolt	kN	kA 1s	kg
	A	B	C	D					
4268.10	350 - 470	20	19	20	M20	19	160	15	2,56
4268.14	540 - 790	20	19	20	M20	19	185	18	3,88
4268.11/10/1	405 - 530	20	19	20	M24	19	240	22	3,48
4268.11	410 - 535	20	19	24	M24	22	240	25	3,79
4268.11/2	560 - 810	20	19	20	M24	19	240	25	4,90
4268.13/2/S	440 - 575	20	19	24	M27	22	280	35	5,03
4268.12/2	565 - 815	20	19	24	M27	22	280	35	6,41
4268.46/2	470 - 640	20	19	20	M30	19	240	40	6,60
4268.46/1	470 - 640	20	19	24	M30	22	320	40	6,70
4268.52/5	470 - 640	20	19	20	TR30	19	240	40	5,90
4268.52	470 - 640	20	19	24	TR30	22	320	40	6,65
4268.52/2	450 - 600	20	19	20	TR32	19	230	40	7,30
4268.52/1	450 - 600	20	19	24	TR32	22	300	50	7,60

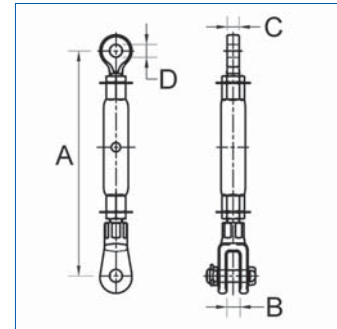

The screws of the turnbuckles are locked by security split pins. To show the full (maximum) extent of the screw length coloured marking is visible. Turnbuckles must not be subjected to a bending load.

Other types are available upon request.



Turnbuckle clevis-clevis

material: steel, forged, hot dip galvanized

L.-Nr.	dimensions in mm			thread	bolt	kN	kA 1s	kg
	A	B	C					
4268.20	400 - 520	20	50	M20	19	160	18	3,20
4268.20/1	500 - 710	20	50	M20	19	160	18	3,78
4268.21/1	430 - 555	20	50	M24	19	240	25	4,30
4268.21/2	560 - 810	20	50	M24	19	240	25	5,40
4268.21/4	900 - 1500	20	50	M24	19	210	25	8,06
4268.22	470 - 605	20	56	M27	22	280	35	5,76
4268.22/1	590 - 840	20	56	M27	22	280	35	7,10
4268.52/6	480 - 650	20	56	TR30	22	320	40	6,90
4268.0002	460 - 610	20	56	TR32	22	300	50	7,50

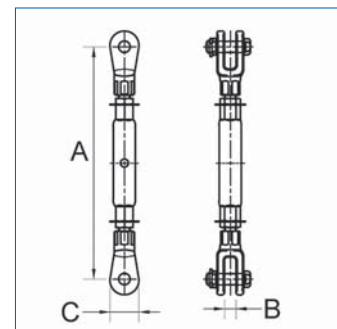

The screws of the turnbuckles are locked by security split pins. To show the full (maximum) extent of the screw length coloured marking is visible. Turnbuckles must not be subjected to a bending load.

Other types are available upon request.



46

Triangular yoke bended

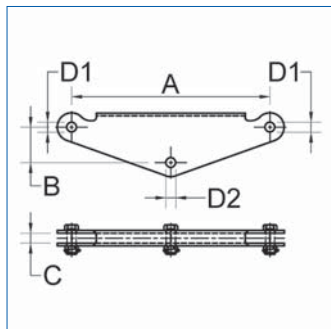

material: steel, hot dip galvanized

L.-Nr.	dimensions in mm					kN	kA 1s	kg
	A	B	C	D1 bolt	D2 bolt			
4270.02/1	280	50	20	19	19	70	16	1,72
4274.05	400	42	20	19	19	160	32	4,37
4274.10	400	42	20	19	19	200	40	5,64
4274.10/2	400	37	20	22	22	250	50	5,55
4270.19/3	400	60	20	22	22	280	50	8,15
4270.19/1	400	60	20	19	22	320	50	7,40
4270.27/1	450	68	20	19	19	210	40	6,28
4270.26	450	68	20	22	22	280	50	8,30
4270.25/1	450	68	20	19	22	320	50	8,80
4274.15	500	66	20	19	19	150	32	5,97
4274.20/2	500	61	20	22	22	230	50	7,50
4270.30/1	600	90	20	19	19	230	40	9,70

Additional holes for attaching arcing devices and for applying tools in case of hot line work are possible.

Other types are available upon request.

Triangular yoke welded

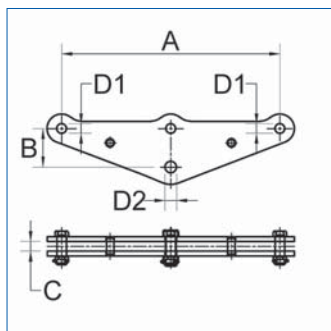

material: steel, hot dip galvanized

L.-Nr.	dimensions in mm					kN	kA 1s	kg
	A	B	C	D1 bolt	D2 bolt			
4270.03/12	330	47	20	19	19	120	32	3,00
4270.17/11	400	70	20	19	19	160	40	5,40
4270.17/18	400	80	20	19	19	160	40	5,50
4270.17/13	400	110	20	19	19	160	40	6,50
4270.17/16	400	80	20	19	19	200	40	6,40
4270.19/13	400	70	20	19	19	240	40	6,30
4270.0033	450	70	20	19	19	210	40	5,50
4270.24/4	500	80	20	19	19	200	40	7,80
4270.24/10	500	100	20	19	19	200	40	8,30

Additional holes for attaching arcing devices and for applying tools in case of hot line work are possible.

Other types are available upon request.

Triangular yoke plate

material: steel, hot dip galvanized

L.-Nr.	dimensions in mm					kN	kA 1s	kg
	A	B	C	D1	D2			
4276.0165	300	50	19	20	20	120	40	4,00
4276.0130	330	50	19	20	20	120	40	4,30
4276.0146	330	80	19	20	20	200	40	5,10
4276.0066	400	60	19	18	18	120	25	4,80
4276.0359	400	75	19	18	18	160	40	4,60
4276.05/1	400	100	19	20	20	200	40	5,80
4276.05/4	400	100	19	24	24	230	50	7,70
4276.0134	400	100	19	20	20	240	40	5,80
4276.07/7	400	100	19	20	24	320	50	6,50
4276.05/3	400	100	20	24	30	460	50	8,50
4276.0055	450	100	19	20	20	240	40	7,30
4276.06/3	450	100	19	20	20	240	40	7,80
4276.06/27	450	100	19	20	24	240	40	7,80
4276.0088	450	100	19	20	24	300	40	7,50
4276.0084	450	100	19	20	24	320	40	6,80
4276.06/8/1	450	100	19	20	24	340	50	7,60
4276.0399	450	100	19	24	24	340	50	4,90
4276.0393	450	100	19	24	24	340	50	8,20
4276.06/2	450	100	22	20	30	420	40	9,75
4276.06/17	457	100	19	20	20	120	40	6,65
4276.06/6	457	100	19	20	20	120	40	8,00
4276.06/20	457	100	16	20	20	160	40	6,70
4276.06/4	457	100	19	20	20	180	40	8,00
4270.0049	457	100	19	20	20	240	40	8,00
4276.0256	457	100	19	20	24	320	40	6,30
4276.09/11/1	500	130	19	20	24	120	40	7,50
4276.09/11	500	130	19	20	24	120	40	9,10
4276.09/5/1	500	100	19	18	20	160	40	6,60
4276.0039	500	100	19	20	20	240	40	8,60
4276.0085	500	120	19	20	24	280	50	9,20
4276.09/20	500	100	19	24	24	320	50	8,50
4276.0097	500	100	22	20	27	360	40	10,30
4276.09/13	500	100	20	24	34	420	50	10,60
4276.0136	600	120	19	20	24	320	40	11,50
4276.0198	600	120	20	24	30	460	50	13,30

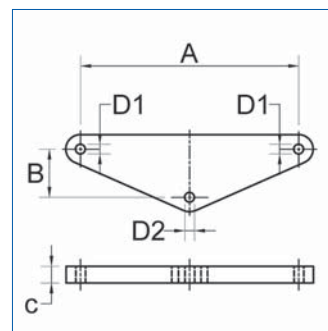

Additional holes for attaching arcing devices and for applying tools in case of hot line work are possible.

Other types are available upon request.

Triangular frame yoke with straps

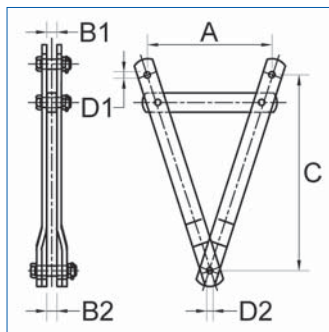

material: steel, hot dip galvanized

L.-Nr.	dimensions in mm						kN	kA 1s	kg
	A	C	B1	B2	D1	D2			
					bolt	bolt			
4280.08/6	400	500	20	20	19	19	240	40	13,40
4280.0021	400	500	20	20	22	22	240	40	13,90
4280.08/1	400	600	20	20	19	19	200	32	12,35
4280.08/2	400	700	20	20	19	19	240	40	16,10
4280.0017	400	1000	20	20	19	19	240	40	20,30
4280.08/7	400	1000	20	20	22	22	240	40	20,60
4280.13/2	500	600	20	20	19	19	200	30	13,20
4280.13/4	500	600	20	20	19	19	240	40	17,50
4280.0003	500	600	20	26	22	28	450	40	18,00
4280.13/6	500	700	20	20	19	19	240	40	16,90
4280.13/7	500	700	20	20	19	22	320	40	17,10
4280.20/4	500	700	20	26	19	27	350	40	17,00
4280.20/3	500	700	20	26	22	27	450	40	20,50
4280.15	600	700	20	26	19	27	350	40	18,00
4280.0044	600	700	20	26	22	32	530	50	23,50
4280.0014	600	700	20	26	22	32	530	50	30,50
4280.18	600	1000	20	22	22	25	340	40	26,50

Additional holes for attaching arcing devices and for applying tools in case of hot line work are possible.

Other types are available upon request.

Trapezoidal yoke bended

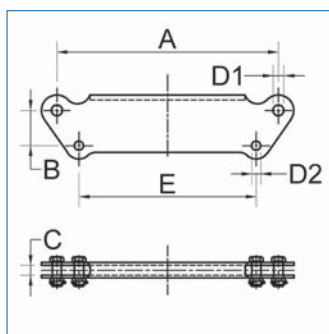

material: steel, hot dip galvanized

L.-Nr.	dimensions in mm						kN	kA 1s	kg
	A	B	C	D1	D2	E			
				bolt	bolt				
4275.10	400	60	20	19	19	100	200	40	6,05
4275.18/3	400	60	20	19	19	200	240	40	6,73
4275.14/2	500	60	20	22	22	100	240	50	8,00
4275.12/2	500	60	20	22	22	200	240	50	7,80
4275.20/3	500	60	20	19	19	400	240	40	8,00
4275.19/7	600	60	20	19	19	400	240	40	9,50

Additional holes for attaching arcing devices and for applying tools in case of hot line work are possible.

Other types are available upon request.

Trapezoidal yoke welded

material: steel, hot dip galvanized

L.-Nr.	dimensions in mm						kN	kA 1s	kg
	A	B	C	D1	D2	E			
				bolt	bolt				
4275.18/1/5	400	75	20	19	19	200	240	40	6,41
4275.0043	400	70	20	20	20	400	320	40	5,70
4275.20/11	500	60	20	19	19	400	240	40	7,19
4275.20/13	500	90	20	19	19	400	240	40	7,40
4275.20/2	500	80	20	22	22	400	360	50	8,90
4275.19/13	600	90	20	19	19	400	240	40	9,15

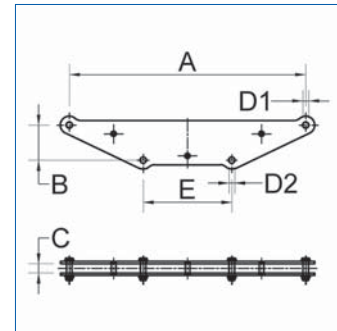

Additional holes for attaching arcing devices and for applying tools in case of hot line work are possible.

Other types are available upon request.



Trapezoidal yoke plate

material: steel, hot dip galvanized

L.-Nr.	dimensions in mm						kN	kA 1s	kg
	A	B	C	D1	D2	E			
4276.24/8	300	80	19	20	20	200	320	40	5,10
4276.24/10	400	100	19	20	20	300	320	40	6,97
4276.0008	500	60	19	20	20	300	160	40	8,00
4276.24/7	500	80	19	20	20	400	320	40	8,50
4276.24/21	500	80	19	24	20	450	460	50	9,10
4276.0242	500	80	19	24	24	450	640	50	9,30
4276.0195	600	80	19	20	20	450	420	40	9,70
4275.0054	600	100	19	20	20	457	320	40	13,20

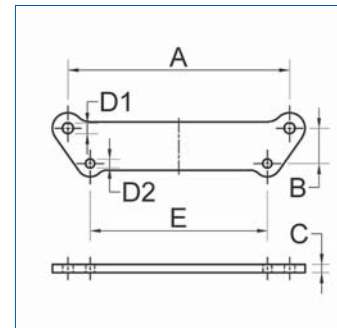

Additional holes for attaching arcing devices and for applying tools in case of hot line work are possible.

Other types are available upon request.



50

Yoke for triple bundle v-string

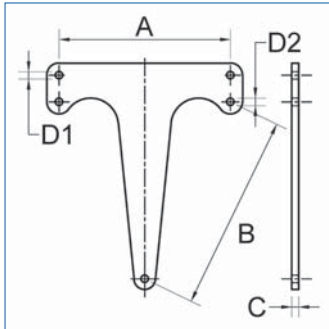

material: steel, hot dip galvanized

L.-Nr.	dimensions in mm					kN	kA 1s	kg
	A	B	C	D1	D2			
4276.29	340	400	19	20	18	210	40	11,70
4276.29/4	400	400	16	20	18	210	40	8,50
4276.0133	405	450	19	20	20	160	40	11,90
4276.31/7	480	457	19	20	20	210	40	13,90
4276.35	500	500	19	20	18	320	40	0,00
4276.35/1	513	500	19	20	18	320	40	18,80

Additional holes for attaching arcing devices and for applying tools in case of hot line work are possible.

Other types are available upon request.

Yoke for triple bundle i-string

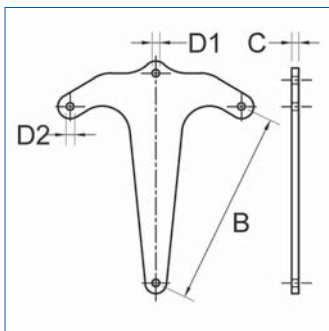

material: steel, hot dip galvanized

L.-Nr.	dimensions in mm				kN	kA 1s	kg
	B	C	D1	D2			
4276.29/5	400	16	20	18	120	40	7,60
4276.31/10	450	19	20	20	210	40	10,60
4276.33/3	457	19	20	18	160	40	9,50
4276.35/6	500	19	20	18	210	40	11,90

Additional holes for attaching arcing devices and for applying tools in case of hot line work are possible.

Other types are available upon request.

Yoke for quad bundle

v-string

material: steel, hot dip galvanized

L.-Nr.	dimensions in mm					kN	kA 1s	kg
	A	B	C	D1	D2			
4276.32/11	330	400	19	24	20	360	50	16,10
4276.32/23	400	400	16	24	18	160	50	13,60
4276.0048	400	450	16	20	18	120	40	13,00
4276.32/18	450	450	19	20	20	160	40	18,70
4276.0219	450	450	16	24	18	180	50	16,20
4276.32/21	400	457	19	22	18	160	40	14,20
4276.32/8	457	457	19	20	20	240	40	20,50

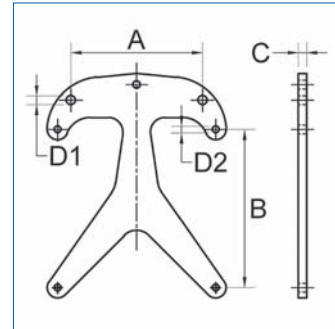

Additional holes for attaching arcing devices and for applying tools in case of hot line work are possible.

Recesses for applying tools in case of hot line work are possible.

Other types are available upon request.

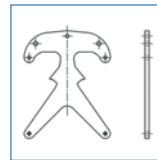

Yoke for quad bundle

i-string

material: steel, hot dip galvanized

L.-Nr.	dimensions in mm				kN	kA 1s	kg
	B	C	D1	D2			
4276.0104	400	19	20	20	120	40	16,10
4276.32/19/1	400	19	20	20	210	40	15,50
4276.32/34	450	16	20	18	120	40	14,60
4276.0241	450	19	24	20	230	50	18,20
4276.0266	450	19	30	20	230	63	18,20
4276.32/22	457	19	22	18	160	40	16,70
4276.32/1/1	457	16	26	22	160	40	18,50
4276.32/30	457	19	20	20	210	40	19,10

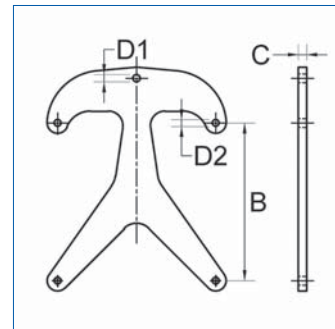

Additional holes for attaching arcing devices and for applying tools in case of hot line work are possible.

Recesses for applying tools in case of hot line work are possible.

Other types are available upon request.

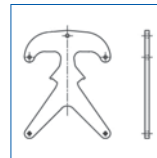

52

Yoke plate with damping straps for rigid V-strings

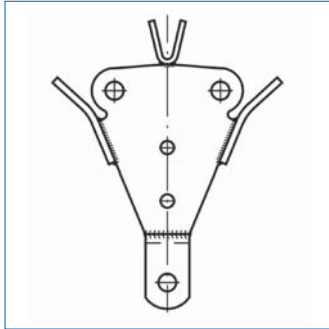

Rigid V-strings will be used for suspension towers and angle towers with angles of up to 10°. Thanks to the damping system based on the yoke plate and the suspension hinges, loads with a high horizontal predominance can also be controlled.

Yoke plates

for V-strings, inverse V-strings and Y-strings

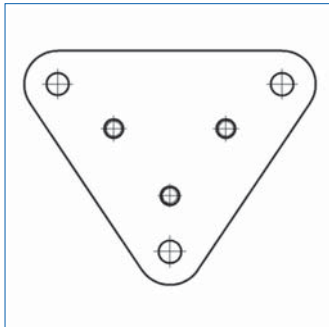

V-strings with small angles will, as a rule, be equipped with long rod insulators and are rigid. Depending on the application, there are many models. Here are two examples:

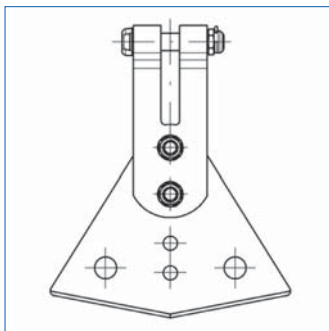

Triangular yoke with a damping tongue for suspension strings

If one string breaks, the yoke will be swivelled to its final position, the damping tongue being bent over the two bolts. The damping tongue has been dimensioned so as to make sure that it will remain in the elastic area at the maximum displacement angle due to wind loads.

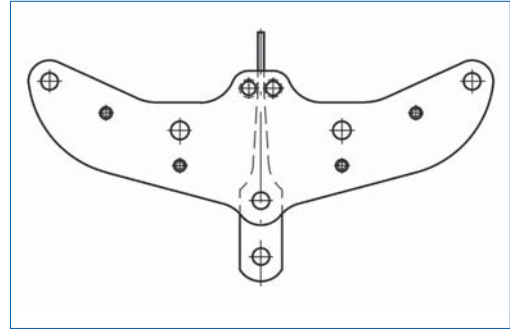

Frame yoke with a damping tongue for tension strings

The effect of the long frame, which is due to the lower change in length at the swivelling-in movement, is reinforced by bending the damping tongue. In this case, no impact of wind displacement is opposed to optimal design.

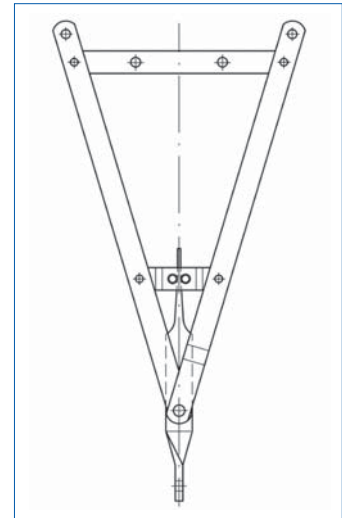

54

Shifting yoke in trapezoidal and triangular form for tension strings

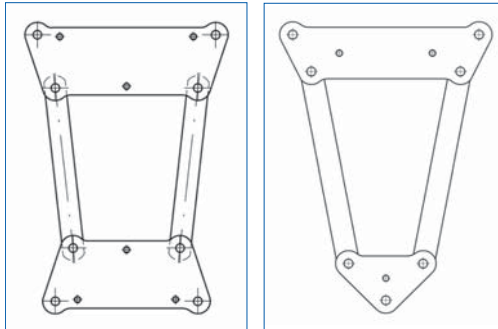

Here force is introduced in a balanced manner. As for the trapezoidal yoke, the mobility of the system will also help to reduce loads in case of rupture of a string. This arrangement is also suitable for calculation.

Displacement yoke with damping elements for tension strings for all conductor configurations

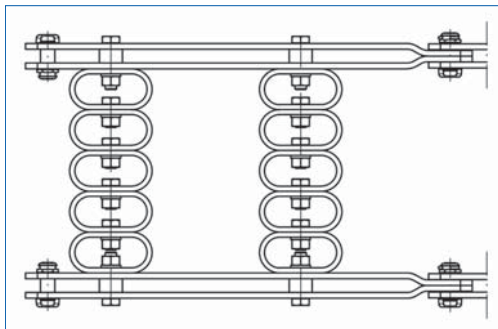

The concept of separate conductor suspension, which had been developed for suspension strings, was implemented in that the yoke, which only consists of displacement elements, will be very flexible in case of transposition. Nevertheless, a safe live connection of the two insulator strings is guaranteed at normal operation.

Yoke with hinge for tension strings for connecting a triple bundle with a double string

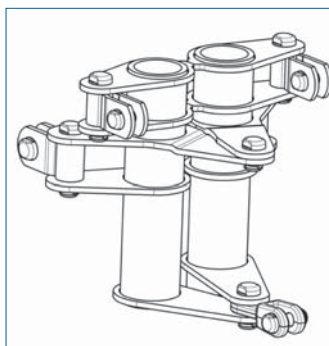

At normal operation, the yoke will act as one single rigid yoke that distributes load. If a string breaks, this yoke will fold open and thus enable thrust displacement of a displacement yoke with damping elements.

Rotary spacer with damping links

for suspension strings with horizontal twin bundle conductors and for four bundle conductors

The idea behind this is that each of the conductors arranged horizontally is separately fixed to an insulator. The live connection of the insulator is provided by the rotary spacers arranged at a distance of approx. 1 m. If one string breaks, the loads will be transmitted from the intact string extremely gently.

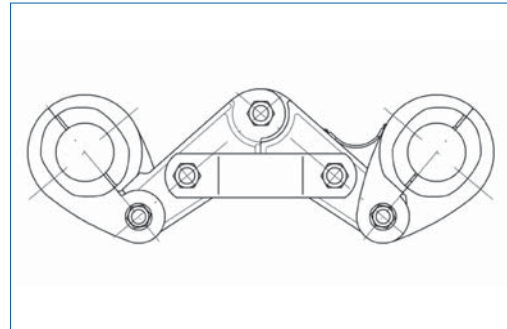

Flapping yoke for suspension strings

for connecting a triple bundle to a double string

For triple bundles, single fastening of the conductors to 2 insulators is not possible. The yoke that will fold open in case of load transposition and can also be equipped with damping elements will enable gentle transmission of the loads.

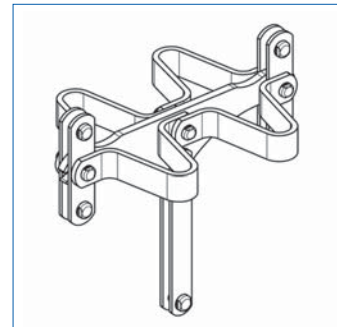

Unhingeable yoke with slots on the side

for suspension strings
for all conductor configurations

In case of transposition, the whole yoke will be drawn out of the connection, the conductors remaining connected to the remaining insulator string over the displacement elements. The slots on the side have been conceived as to make sure that there cannot be any uncoupling at maximum wind displacement.

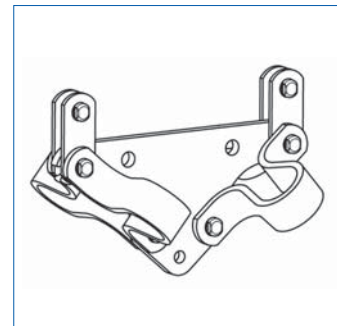

56

Yoke with shifting slots
with displacement elements for tension strings
for all conductor configurations

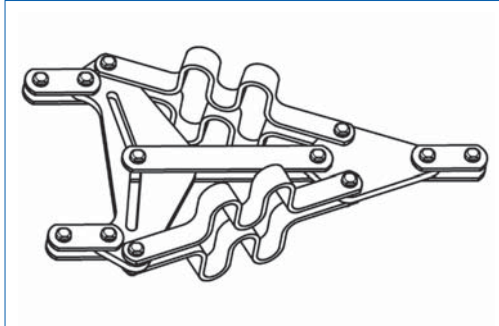

This type of yoke enables large-area displacement of the damping elements, which is provided by the sliding slot. The displacement elements can be wave shaped or meandering.