

4

SUSPENSION CLAMPS



57

Contents

General	58
Suspension clamp trunnion type, forged, for aluminium based conductors	63
Suspension clamp trunnion type, forged, with bigger angle of deflection, for aluminium based conductors	63
Suspension clamp with bolt, forged, for aluminium based conductors	64
Suspension clamp with steel strap as trunnion, casted, for aluminium based conductors	64
Suspension clamp with bolt, casted, for aluminium based conductors	65
Suspension clamp with bolt, casted, with shackle, for aluminium based conductors	65
Suspension clamp envelope type casted, for aluminium based conductors	66
Suspension clamp envelope type trunnion type, casted, for aluminum based conductors	66
HSU trunnion type, forged, for aluminium based conductors	67
HSU with aluminium belt, casted, for aluminium based conductors	68
Compact suspension clamp trunnion type, forged, with line guards, for aluminium based conductors	69
Compact suspension clamp trunnion type, forged, with armor rods, for aluminium based conductors	70
Counter weight	71



Bosporus Crossing: Double I-insulator string with a saddle type suspension clamp

General

Suspension clamps support and connect conductors onto insulator strings.

Information for ground wire suspension clamps, including fibre optic cables (OPGW - optical ground wires) and ADSS (all-dielectric self-supporting) cables can be found in **Parts 8 and 18** of the catalogue.

Suspension clamps provide the following:

- A safe mechanical connection in all conditions. This includes all ruling span stresses at maximum working loads combined with controlled grip of longitudinal tension that provides protection. Suspension clamps also provide longitudinal grip control, releasing the conductor at the suspension clamps at defined slip loads to prevent damage.
- The clamps are designed to protect the conductor at line design installation loads.
- Suspension clamps incorporate controlled movement for added conductor protection against wind induced vibration and oscillation.
- High electrical current short circuit loads are transmitted through arcing devices attached to string hardware protecting the suspension system. For more details, please refer to Part 3 of the catalogue.
- The outer profile clamp shapes are designed to reduce electrical discharge to below maximum specified corona extinction voltages. These values are also influenced by conductor bundle configuration, and must also be considered.

Material

- All materials used are fully compatible with the conductor application. For example, clamps attached to aluminium based conductors are manufactured from high strength corrosion resistant aluminium alloys.
- Unless otherwise specified, all ferrous components are hot dipped galvanized acc. to *EN 61284* or *ISO EN 1461*; Overhead lines-requirements and tests for fittings. Where stainless steel fasteners are used, *ISO EN 3506*; Mechanical properties of corrosion resistant stainless steel fasteners - Part 1: Bolts, screws and studs are specified.
- **For special cases where big dynamic loads may occur at low temperatures, fittings made of low-temperature (cryogenic) steels are available.**
- **For lines constructed in higher corrosive atmospheres and environments, the minimum zinc thickness of fittings can be increased from 85 μ to 110 μ or 130 μ Microns.**
- All fitting assemblies supplied have **identification marking** according to *EN 61284*; this includes manufactures mark and date code, specified minimum mechanical failure load, and 1 second short circuit current withstand rating.

4

SUSPENSION CLAMPS

- Eye-clevis connections are designed acc. to *IEC 61471* and *DIN 48074* - Eyes and clevises; connecting dimensions, Bolts acc. to *DIN 48073* - Connecting bolts for overhead power lines.
- Bolt security split pins are manufactured in stainless steel. Copper tin-plated types can be also be supplied.

Counter Weights can be specified to restrict displacement angles to maintain ground earth clearances and avoid conductor uplift.

There are several attachment options:

- Counterweight devices can be mounted using elongated bolts.
- For vertical twin and quadruple bundles, weights can be mounted onto the connecting straps.

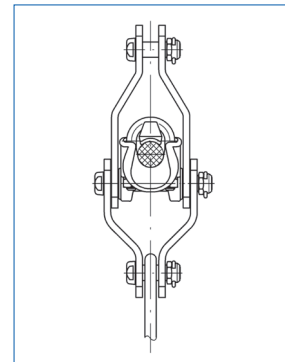

Example of a suspension device for counterweights

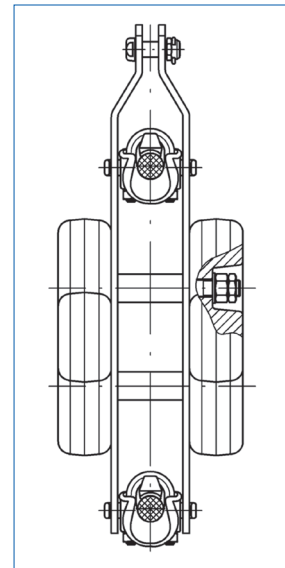

Example of the assembly of counterweights

- Counterweights can also be mounted onto conductor bundle spacers in Jumper Loops. (See also **Part 9**)

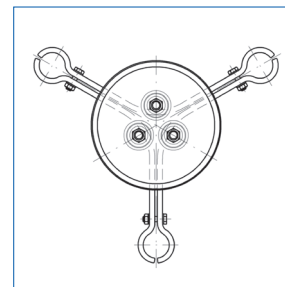

Arrangement of counterweights for jumper loops

- Counterweight clamp attachments may reduce earth grounding clearances. If space restrictions apply, counterweights can be mounted directly onto the conductor.

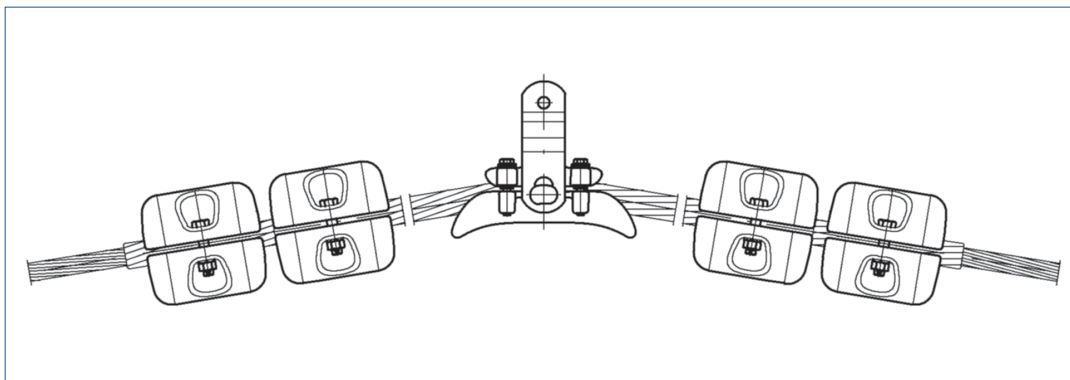

Counterweights for conductors

The following catalogue pages provide an overview of the types of suspension clamp most commonly used. For more specialised requirements, suspension clamp designs accommodate specific line protection features.

Releasing suspension clamp (left) and Characteristic force-time behaviour (right)

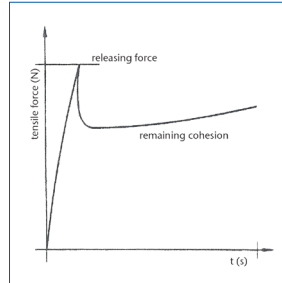
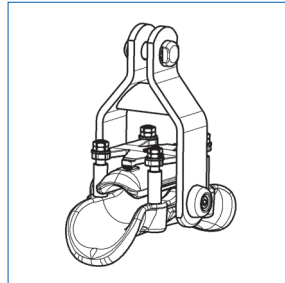

Controlled slip suspension clamps

This type allows controlled axial cable slip forces to be precisely adjusted to allow controlled cable release at specified loads. Axial grip and slip displacement is maintained following high imbalanced span loadings e.g; impact or ice shedding loads on adjacent spans.

Suspension clamps for wide-span fields

For longer spans, double clamp types can be specified for higher strength and reduced cable bending stresses by reducing cable angle deviation at suspension points.

Saddle type suspension clamps, manufactured from high strength corrosion resistant aluminium alloys, are contoured at the cable connection interface to reduce support stresses, and are also recommended for long span high line angle deviation routes. This type can also be offered

Double-suspension string with a saddle type suspension clamp (left) and Saddle type suspension clamp at a vibration test in the laboratory (right)

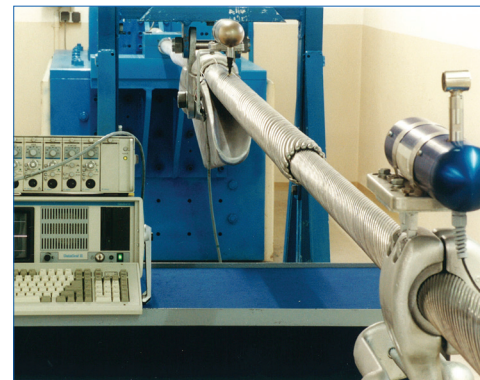
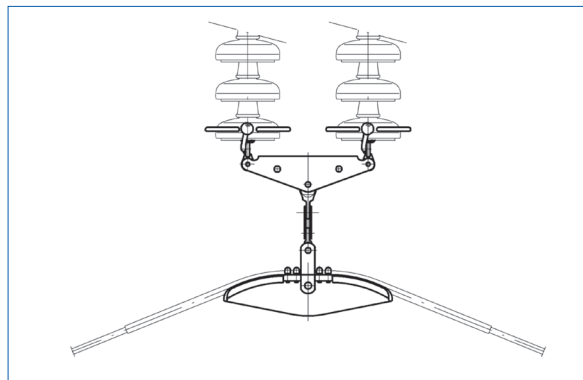

as a controlled slip load clamp.

Both clamp types have proven reliability and long service life with multiple power network operators.

Heat cycle test with suspension clamps for high-temperature conductors



Suspension clamps for high-temperature conductors

As power requirements increase, high-temperature carrying conductors with a capacity of up to 235°C will be more common.

However, the clamps used for these conductors must not be affected by high temperatures and maintain strength and mechanical performance.

It is therefore necessary to increase the mass and surface area of clamp designs to reduce thermal stresses. This is preferably accomplished by the use of Armour Rods.

Long-term testing demonstrates the effectiveness of these developments. These tests also prove suitability of different types of high temperature conductor's e.g. where the steel core has a gap arranged loosely inside the conductor (e.g. GAP GZTACSR conductor).

Suspension clamps for bundle conductors, for vertical twin and quadruple bundles

All types of clamps can be used in multiple string configurations with specific bundle spacings. Different types of counterweight can be adapted for direct or indirect connection to conductors.

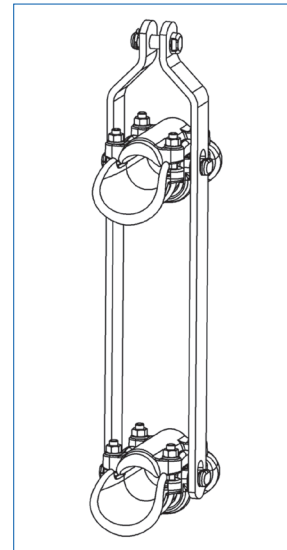

Suspension clamp for a vertical twin bundle

Special models of suspension clamps

For changing between different bundle shapes or for substation feeds, special designs may be necessary.

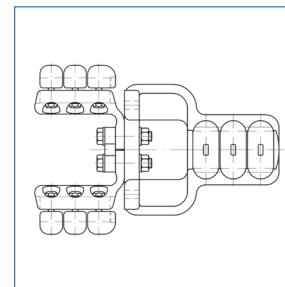
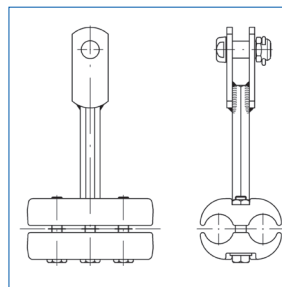

Parallel groove clamp as suspension clamp (left) and an example of the changing from a twin bundle to a triple bundle (right)

Helical Suspension Unit

In the clamping area, the conductor will be surrounded by a neoprene insert of concave shape preventing the conductor from slipping under longitudinal tension. The helically formed rods wound around the neoprene insert are gripped by the main clamping body.

There are two basic types available.

A forged aluminium main body type, with steel axle pivots screwed and pressed into the body at the conductor centre line, easing installation. The main bodies are hinged and clamped by a conventional bolt, attached by steel straps to the pivots and insulator string.

A conventional cast aluminium body type is secured and connected together by a high strength aluminium strap, with a clevis bolt string attachment above the conductor.

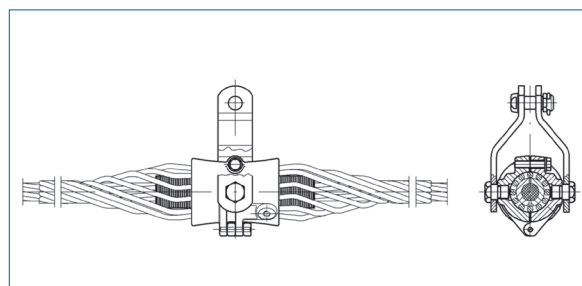

HSU clamp with a connection to the centre

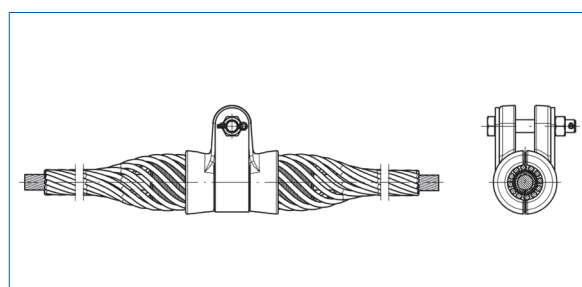

HSU clamp with an aluminium belt

Helical wire fittings

Helical wire fittings are made of formed round wire rods, with the ends shaped depending on the material and diameter. The formed diameters of the wires are smaller than the diameter of cable to be applied. This creates uniform radial pre compression of the spiral without permanent distortion of the wires or sub-sets. This applies the initial low stress grip of the cable, which increases as a resultant of higher tension forces that convert to high frictional grip. Uniform radial loads and grip increase over a longer application and contact length that provide low relative and uniform radial stress.

Suspension points have reinforcing rods with larger suspension clamps applied. Special short-suspension clamps or helical supporting units (HSU's) with integrated armour rods will also be used.

Identification and labelling of products are in accordance with; *IEC 61284* (Rules of behaviour with respect to possible hazards when dealing with electric equipment and equipment employing similar techniques) will either be printed on individual rod sets or stated on a label connected to the set.

The lay direction of the helical rods is normally same as that of the outermost layer of the conductor, typically right hand lay.

The material used is the same as that in the outer layer of the conductor.



Example of
a HSU clamp

4

SUSPENSION CLAMPS

Suspension clamp trunnion type, forged
for aluminium based conductors

material: aluminium, forged; steel, hot dip galvanized

L.-Nr.	dimensions in mm					kN	kA 1s	kg
	cond.Ø	A	B	C	bolt			
4334.0023	23,1 - 29,5	250	130	20	19	100	40	3,10
4334.0024	29,0 - 36,0	300	150	20	19	120	40	3,70
4334.0022	29,0 - 36,0	300	150	20	22	120	40	3,80
636.07/121A	35,0 - 52,0	250	140	20	22	120	40	3,90
4334.0036/1	50,1 - 57,5	300	150	20	19	150	40	5,20
4334.0036	50,1 - 57,5	300	150	20	22	150	50	5,30

Other dimensions are available upon request.

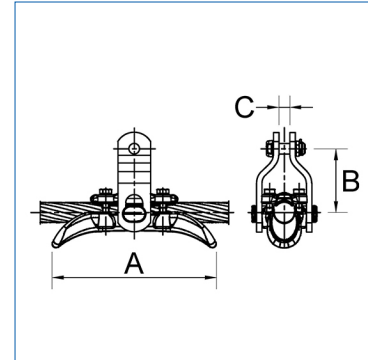

Suspension clamp trunnion type, forged, with bigger angle of deflection
for aluminium based conductors

material: aluminium, forged; steel, hot dip galvanized

L.-Nr.	dimensions in mm				bolt	kN	kA 1s	kg
	cond.Ø	A	B	C				
636.03/203	14,0 - 16,5	256	110	20	19	100	40	2,95
636.04/203	19,0 - 21,8	310	110	20	19	110	32	3,14
636.05/204	24,0	280	110	20	22	125	32	3,17
636.06/204	32,0	305	120	20	22	175	50	4,45
636.08/204	39,2	334	135	20	22	260	50	5,33

The fact that the conductor cavity is prolonged will lead to a bigger angle of departure of the conductor.

Other dimensions are available upon request.

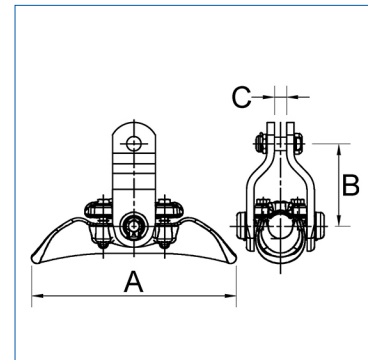

64

Suspension clamp with bolt, forged for aluminium based conductors

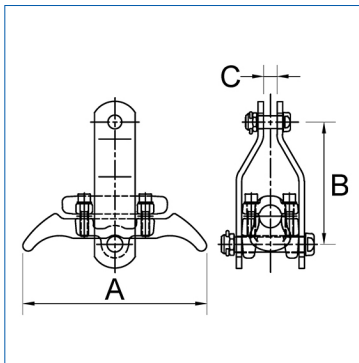

material: aluminium, forged; steel, hot dip galvanized

L.-Nr.	dimensions in mm					kN	kA 1s	kg
	cond.Ø	A	B	C	bolt			
637.02/102	9,0 - 14,0	140	90	20	19	55	18	1,07
637.03/101	13,5 - 17,5	170	100	20	19	50	20	1,37
637.04/104	18,5 - 23,0	190	125	20	19	85	30	2,09
637.05/11	21,2 - 23,4	220	140	20	19	85	30	2,44
637.05/21	23,5 - 25,7	250	160	20	19	130	30	3,00
637.06/10	25,8 - 28,1	250	160	20	19	130	30	2,95
637.06/602	28,1 - 30,0	250	160	20	19	130	30	2,94
637.07/1	30,1 - 32,8	270	170	20	22	130	30	3,80
637.07/21	33,0 - 36,0	300	190	20	19	150	40	4,95
637.07/23	36,1 - 39,0	300	190	20	22	150	50	5,07
637.07/25	40,0 - 44,0	300	190	20	22	150	50	4,80

Other dimensions are available upon request.

Suspension clamp with steel strap as trunnion, casted for aluminium based conductors

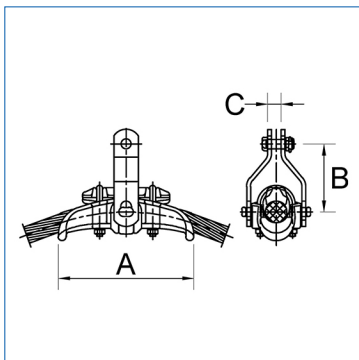

material: aluminium, casted; steel, hot dip galvanized

L.-Nr.	dimensions in mm					kN	kA 1s	kg
	cond.Ø	A	B	C	bolt			
4335.07/20	25,0 - 32,0	250	130	20	19	130	32	3,15
4334.08	43,0 - 52,0	280	150	20	19	160	30	4,12
4334.0030	52,0 - 62,0	300	150	20	18	160	35	5,50

Other dimensions are available upon request.

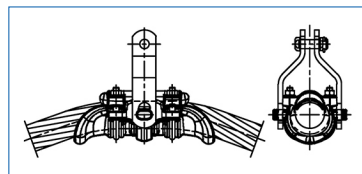

4

SUSPENSION CLAMPS



65

Suspension clamp with bolt, casted
for aluminium based conductors

material: aluminium, casted; steel, hot dip galvanized

L.-Nr.	dimensions in mm			bolt	kN	kA 1s	kg
	cond.Ø	A	B				
4335.04/1	9,0 - 16,5	210	115	20	80	18	1,90
4335.05/1	16,5 - 22,1	230	133	20	19	100	2,38
4335.06	21,0 - 25,0	250	145	20	19	120	2,91
4335.07	25,0 - 32,0	250	165	20	19	130	3,10
4335.11	32,0 - 36,0	270	182	20	19	120	3,95
4335.16	36,0 - 47,0	290	185	20	19	160	4,50

Other dimensions are available upon request.

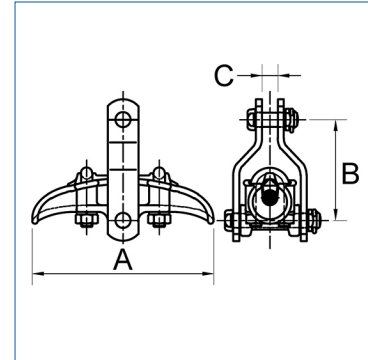

Suspension clamp with bolt, casted, with shackle
for aluminium based conductors

material: aluminium, casted; steel, hot dip galvanized

L.-Nr.	dimensions in mm			kN	kA 1s	kg
	cond.Ø	A	B			
4326.01	9,0 - 16,5	210	80	80	18	1,60
4337.9001	15,0 - 18,5	190	133	100	32	2,90

Other dimensions are available upon request.

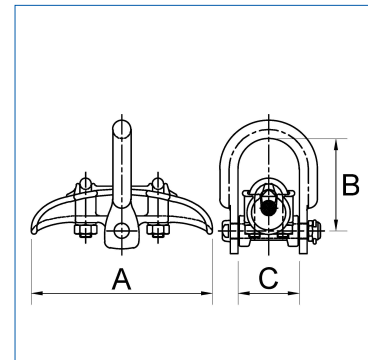

Suspension clamp envelope type casted for aluminium based conductors

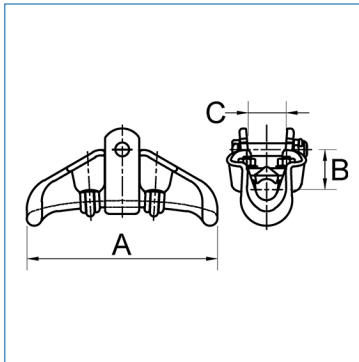

material: aluminium, casted; aluminium extruded; steel, hot dip galvanized

L.-Nr.	dimensions in mm					kN	kA 1s	kg
	cond.Ø	A	B	C	bolt			
4301.10	24,0 - 32,0	280	90	50	19	120	40	2,48
4301.11	32,0 - 36,5	280	90	50	19	100	40	2,40
4301.12	36,0 - 43,0	280	125	55	19	120	40	2,91
4301.13/0	43,0 - 53,0	280	95	60	19	120	40	3,20
4301.14	53,0 - 65,0	340	125	82	22	140	50	4,90

These types with a connecting bolt at the top have a shape that means the clevis widths do not conform to the IEC recommendation. Therefore, a connecting piece, e.g. a hinge, will be required in addition.

Rounding off guarantees a high corona resistant performance.

Other dimensions are available upon request.



Suspension clamp envelope type trunnion type, casted for aluminum based conductors

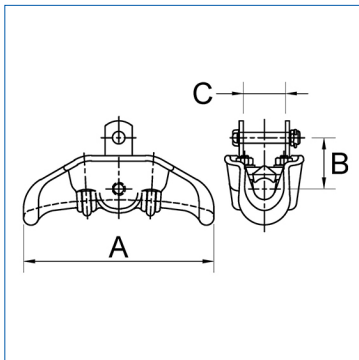

material: aluminium, casted; steel, hot dip galvanized

L.-Nr.	dimensions in mm					kN	kA 1s	kg
	cond.Ø	A	B	C	bolt			
4301.0010	32,0 - 36,5	280	75	62	16	120	25	3,30

These types with a connecting bolt at the top have a shape that means the clevis widths do not conform to the IEC recommendation. Therefore, a connecting piece, e.g. a hinge, will be required in addition.

The steel eyes of these suspension clamps are fixed in the housing by means of a steel strap. This fixing point is in line with the conductor axis. Rounding off guarantees a high corona resistant performance.

Other dimensions are available upon request.



4

SUSPENSION CLAMPS

HSU trunion type, forged
for aluminium based conductors

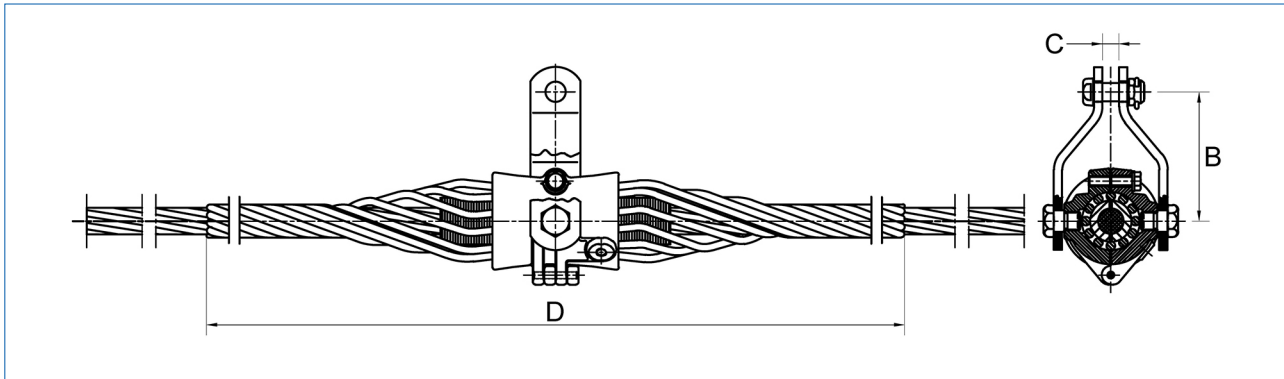

material: aluminium, forged; aluminium-rods; steel, hot dip galvanized; neoprene

L.-Nr.	dimensions in mm				bolt	kN	kA 1s	kg
	cond.Ø	B	C	D				
4361.07	12,24 - 12,69	90	20	1020	19	80	32	2,00
4361.08	12,70 - 13,02	90	20	1020	19	80	32	1,70
4361.09	13,03 - 13,48	90	20	1040	19	80	32	1,70
4361.10	13,49 - 13,78	90	20	1040	19	80	32	1,70
4361.11	13,79 - 14,11	90	20	1120	19	80	32	2,00
4361.12	14,12 - 14,57	90	20	1120	19	80	32	2,00
4361.13	14,58 - 15,10	90	20	1140	19	80	32	2,10
4361.14	15,11 - 15,41	90	20	1170	19	80	32	2,10
4361.15	15,42 - 15,74	90	20	1170	19	80	32	2,10
4361.19	15,55 - 18,05	90	20	1370	19	80	32	2,70
4361.16	15,75 - 16,40	90	20	1270	19	80	32	2,20
4361.17	16,41 - 17,11	90	20	1370	19	80	32	2,70
4361.18	17,12 - 17,54	90	20	1370	19	80	32	2,70
4361.20	18,06 - 18,58	90	20	1400	19	80	32	2,80
4361.21	18,59 - 19,07	90	20	1420	19	80	32	2,80
4361.22	19,08 - 19,52	120	20	1520	19	110	35	4,00
4361.23	19,53 - 20,21	120	20	1520	19	110	35	4,10
4361.24	20,22 - 20,95	120	20	1550	19	110	35	4,10
4361.25	20,96 - 21,48	120	20	1630	19	110	35	4,20
4361.26	21,49 - 22,11	120	20	1630	19	110	35	4,20
4361.27	22,12 - 22,70	120	20	1650	19	110	35	4,40
4361.28	22,71 - 23,05	120	20	1650	19	110	35	4,40
4361.29	23,06 - 23,38	140	20	1680	19	120	35	5,20
4361.30	23,39 - 23,82	140	20	1680	19	120	35	5,20
4361.31	23,83 - 24,45	140	20	1700	19	120	35	5,30
4361.32	24,46 - 25,06	140	20	1730	19	120	35	5,50
4361.33	25,07 - 25,54	140	20	1750	19	120	35	5,50
4361.34	25,55 - 25,97	150	20	2030	19	110	35	8,70
4361.35	25,98 - 26,43	150	20	2080	19	110	35	8,70
4361.36	26,44 - 27,30	150	20	2080	19	110	35	8,70
4361.37	27,31 - 27,70	150	20	2080	19	110	35	7,90
4361.38	27,71 - 28,41	150	20	2080	19	110	35	9,00
4361.39	28,42 - 28,87	150	20	2080	19	110	35	7,40
4361.40	28,88 - 29,28	150	20	2080	19	110	35	7,40
4361.41	29,29 - 29,86	150	20	2080	19	110	35	9,00



material: aluminium, forged; aluminium-rods; steel, hot dip galvanized; neoprene

L.-Nr.	dimensions in mm				bolt	kN	kA 1 s	kg
	cond.Ø	B	C	D				
4361.42	29,87 - 30,70	150	20	2080	19	110	35	7,40
4361.43	30,71 - 31,16	155	20	2240	19	120	40	11,10
4361.44	31,17 - 31,99	155	20	2240	19	120	40	11,20
4361.45	32,00 - 32,68	155	20	2240	19	120	40	11,50
4361.46	32,69 - 33,39	155	20	2240	19	120	40	11,50
4361.47	33,40 - 34,43	155	20	2240	19	120	40	11,50

These articles are based on right-hand-layed conductors. Articles for left-hand-layed conductors are available upon request.

The screw type bolts of these clamps have been mounted in line with the conductor axes. This will help to improve mobility and reduce alternating bending strains caused by vibrations. In order to minimize abrasion between the eyes and the screw type bolts, these parts are made of steel. HSU's (heliformed suspension units) can be used for a conductor angle of up to 30°. Conductor angles of up to 60° will be possible if two bodies are connected by a suitable yoke plate via a combined heliformed rod.

This is shown in part 18. Other dimensions are available upon request.

HSU with aluminium belt, casted
for aluminium based conductors

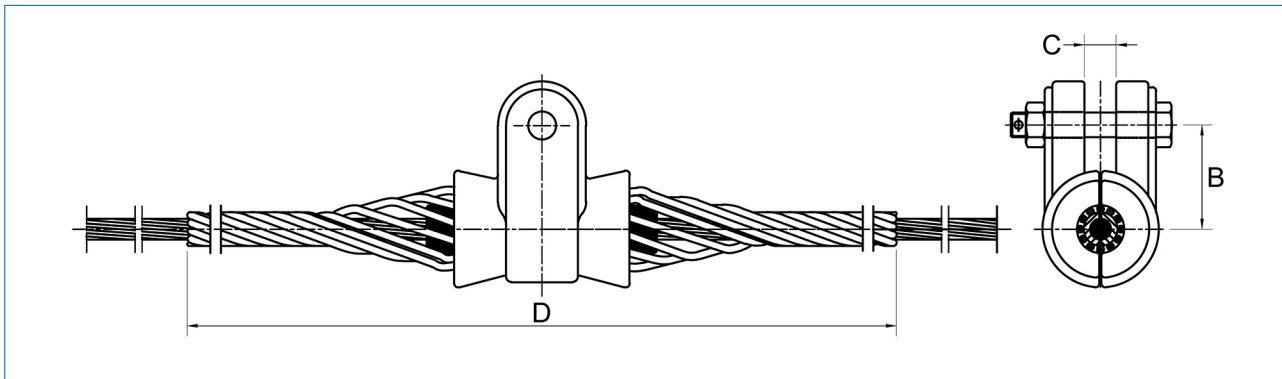

material: aluminium, casted; aluminium, extruded; aluminium-rods; steel, hot dip galvanized; neoprene

L.-Nr.	dimensions in mm				bolt	kN	kA 1 s	kg
	cond.Ø	B	C	D				
4361.04/2/AO	11,05 - 11,45	55	22	910	16	50	25	0,60
4361.06/2/AO	11,96 - 12,23	55	22	910	16	50	25	1,10
4361.07/2/AO	12,24 - 12,69	55	22	1020	16	60	25	1,30
4361.08/2/AO	12,70 - 13,02	55	22	1020	16	60	25	1,30
4361.08/3/AL	12,70 - 13,02	55	22	1800	16	80	25	1,40
4361.09/2/AO	13,03 - 13,48	55	22	1040	16	60	25	1,30
4361.11/2/AO	13,79 - 14,11	53	22	1120	16	70	25	1,50
4361.12/2/AO	14,12 - 14,57	53	22	1120	16	70	25	1,50

material: aluminium, casted; aluminium, extruded; aluminium-rods; steel, hot dip galvanized; neoprene

L.-Nr.	dimensions in mm				bolt	kN	kA 1s	kg
	cond.Ø	B	C	D				
4361.13/2/AO	14,58 - 15,10	53	22	1140	16	70	25	1,60
4361.13/3/AL	14,58 - 15,10	53	22	1800	16	70	25	2,00
4361.14/2/AO	15,11 - 15,41	53	22	1170	16	70	25	1,50
4361.16/2/AO	15,75 - 16,40	53	22	1270	16	70	25	1,60
4361.17/2/AO	16,41 - 17,11	63	22	1370	16	70	25	2,00
4361.18/2/AO	17,12 - 17,45	63	22	1370	16	70	25	2,00
4361.19/2/AO	17,55 - 18,05	63	22	1370	16	70	25	3,30
4361.21/2/AO	18,59 - 19,07	63	22	1420	16	70	25	3,30
4361.22/2/AO	19,08 - 19,52	70	22	1520	16	100	25	1,70
4361.23/2/AO	19,53 - 20,21	70	22	1520	16	100	25	3,30
4361.24/2/AO	20,22 - 20,95	70	22	1550	16	100	25	1,70
4361.25/2/AO	20,96 - 21,48	70	22	1630	16	100	25	4,00
4361.27/2/AO	22,12 - 23,05	70	22	1650	16	100	25	1,70
4361.33/2/AO	25,07 - 25,54	74	22	1750	16	100	25	4,20
4361.34/2/AO	25,55 - 25,97	75	22	2030	16	120	25	4,70
4361.35/2/AO	25,98 - 26,43	75	22	2080	16	120	25	4,70
4361.37/2/AO	27,31 - 27,70	75	22	2080	16	120	25	4,80

These articles are based on right-hand-layed conductors. Articles for left-hand-layed conductors are available upon request.

Clamps with reinforcing rods are available upon request. Other dimensions are available upon request.

Compact suspension clamp trunnion type, forged, with line guards for aluminium based conductors

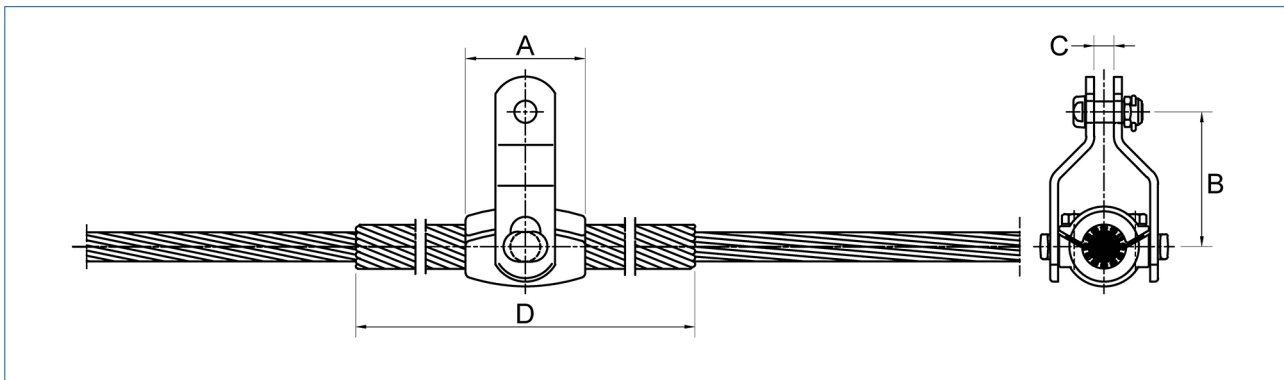

material: aluminium, forged; aluminium-rods; steel, hot dip galvanized

L.-Nr.	dimensions in mm					kN	kA 1s	kg
	cond.Ø	B	C	D	bolt			
4352.08	15,42 - 16,02	115	20	840	19	60	30	2,00
4352.09	16,03 - 16,65	115	20	840	19	60	30	2,00
4352.10	16,66 - 17,26	115	20	890	19	60	30	2,00
4352.11	17,27 - 17,87	135	20	890	19	100	35	2,90

material: aluminium, forged; aluminium-rods; steel, hot dip galvanized

L.-Nr.	dimensions in mm					kN	kA 1 s	kg
	cond.Ø	B	C	D	bolt			
4352.12	17,88 - 18,81	135	20	940	19	100	35	2,90
4352.13	18,82 - 20,13	135	20	990	19	100	35	2,90
4352.14	20,14 - 22,82	135	20	990	19	100	35	3,00
4352.15	20,14 - 22,82	135	20	1040	19	100	35	3,00
4352.16	22,83 - 24,25	135	20	1090	19	100	35	3,20
4352.17	24,26 - 25,06	135	20	1140	19	100	35	3,20
4352.18	25,07 - 25,82	140	20	1140	19	120	35	3,65
4352.19	25,83 - 27,04	140	20	1190	19	120	35	3,70
4352.20	27,05 - 27,90	150	20	1240	19	120	40	4,35
4352.21	27,91 - 29,30	150	20	1240	19	120	40	4,50
4352.22	29,31 - 30,70	150	20	1300	19	120	40	5,10
4352.23	30,71 - 32,22	150	20	1350	19	120	40	5,10
4352.24	32,23 - 33,72	150	20	1350	19	120	40	5,30
4352.25	33,73 - 35,32	150	20	1400	19	120	40	5,30
4352.26	35,33 - 36,59	155	20	1450	19	150	40	6,25
4352.27	36,60 - 38,32	155	20	1500	19	150	40	6,25

These articles are based on right-hand-layed conductors. Articles for left-hand-layed conductors are available upon request.

Other dimensions are available upon request.

Compact suspension clamp trunnion type, forged, with armor rods for aluminium based conductors

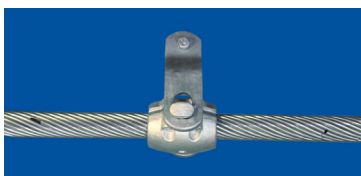
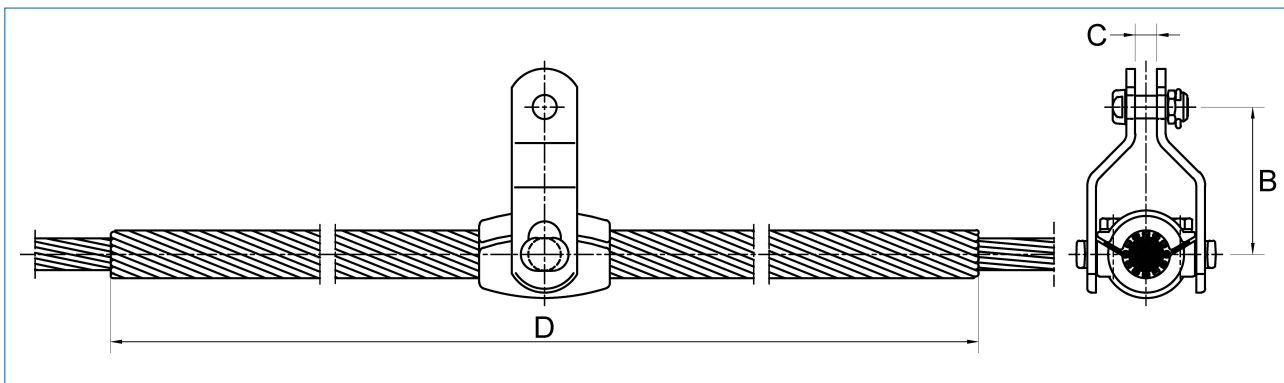

material: aluminium, forged; aluminium-rods; steel, hot dip galvanized

L.-Nr.	dimensions in mm					kN	kA 1 s	kg
	cond.Ø	B	C	D	bolt			
4353.04	11,10 - 11,78	115	20	1370	19	60	30	2,20
4353.05	11,79 - 12,46	115	20	1370	19	60	30	2,20
4353.06	12,47 - 13,25	115	20	1420	19	60	30	2,20
4353.07	13,26 - 14,01	115	20	1470	19	60	30	2,50
4353.08	14,02 - 14,87	115	20	1520	19	60	30	2,50
4353.09	14,88 - 15,41	115	20	1570	19	60	30	2,50
4353.10	15,42 - 16,02	135	20	1630	19	100	35	3,40

4

SUSPENSION CLAMPS

material: aluminium, forged; aluminium-rods; steel, hot dip galvanized

L.-Nr.	dimensions in mm					kN	kA 1s	kg
	cond.Ø	B	C	D	bolt			
4353.11	16,03 - 16,65	135	20	1630	19	100	35	3,40
4353.12	16,66 - 17,26	135	20	1680	19	100	35	3,40
4353.13	17,27 - 17,87	135	20	1730	19	100	35	3,70
4353.14	17,88 - 18,81	135	20	1830	19	100	35	3,70
4353.15	18,82 - 19,88	135	20	1830	19	100	35	3,70
4353.16	19,89 - 20,69	135	20	1930	19	100	35	4,30
4353.17	20,70 - 21,48	135	20	1930	19	100	35	4,30
4353.18	21,49 - 23,05	140	20	1980	19	100	35	2,64
4353.19	23,06 - 23,61	140	20	2030	19	100	35	4,90
4353.20	23,62 - 24,81	140	20	2240	19	100	40	5,80
4353.21	24,82 - 25,82	140	20	2340	19	100	40	6,90
4353.22	25,83 - 26,30	140	20	2390	19	100	40	6,90
4353.23	26,31 - 27,04	150	20	2440	19	120	40	7,50
4353.24	27,05 - 27,90	150	20	2540	19	120	40	7,50
4353.25	27,91 - 28,92	150	20	2540	19	120	40	7,50
4353.26	28,96 - 29,50	150	20	2540	19	120	40	7,50
4353.27	29,51 - 30,70	150	20	2540	19	120	40	7,80
4353.28	30,71 - 32,25	155	20	2540	19	150	40	9,60
4353.29	32,26 - 33,72	155	20	2540	19	150	40	9,60

These articles are based on right-hand-layed conductors. Articles for left-hand-layed conductors are available upon request.

Other dimensions are available upon request.

Counter weight

material: cast iron, hot dip galvanized

L.-Nr.	dimensions in mm		kg
	A	B	
4371.02	350	37	25,00

To be used in combination with counter weight set, which is available upon request.

Other types of counter weights are available upon request.

