

## Contents

General .....	74
Wedge tension clamp without jumper guide, for aluminium based conductors .....	79
Wedge tension clamp with jumper guide, for aluminium based conductors .....	79
Double wedge tension clamp without jumper guide, for aluminium based conductors .....	80
Double wedge tension clamp with jumper guide, for aluminium based conductors .....	81
Bolted type tension clamp, for aluminium based conductors .....	81
Heliformed dead end with thimble and reinforcing rods, for aluminium based conductors .....	82
Compression dead end clamp with eye for ACSR, according to DIN Standard .....	83
Compression dead end clamp with eye for ACSR, according to international standards .....	84
Compression dead end clamp with clevis for ACSR, according to DIN Standard .....	84
Compression dead end clamp with clevis for ACSR, according to international standards .....	85
Compression dead end clamp with eye for AAAC, according to DIN Standard .....	86
Compression dead end clamp with eye for AAAC, according to international standards .....	86
Compression dead end clamp with clevis for AAAC, according to DIN Standard .....	87
Compression dead end clamp with clevis for AAAC, according to international standards .....	87
Compression dead end clamp with eye, for steel and ACS-conductor .....	88
Compression dead end clamp with clevis, for steel and ACS-conductor .....	88
Compression joint for ACSR, according to DIN Standard .....	89
Compression joint for ACSR, according to international standards .....	90
Compression joint for AAAC, according to DIN Standard .....	91
Compression joint for AAAC, according to international standards .....	91
Compression joint, for steel and ACS-conductor .....	92
Repair sleeve, for aluminium based conductors .....	92
Repair sleeve, for steel and ACS-conductor .....	93

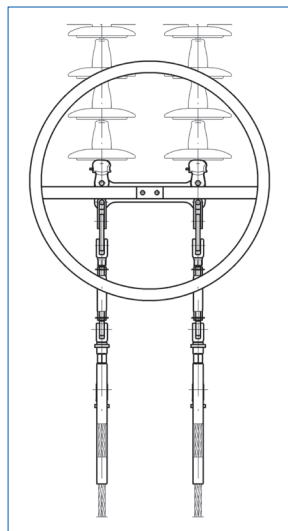

400 kV tension tower: 2 systems for a quadruple bundle



Tension string with corona ring

## General

Tension clamps connect conductors to tension strings and withstand the required mechanical holding forces.

A distinction is made between two types of tension clamps, which have fundamental differences:

- Disconnectable clamps, such as wedge tension clamps, bolted type tension clamps, helical dead ends and strain thimbles, can all be adjusted;
- Compression dead end clamps, are permanent connections, and cannot be adjusted for span, sag, or tension adjustments.

Tension clamps must fulfil the following tasks:

- A mechanical connection that safely withstands tension loads in all operating cases. This requires a minimum mechanical failing load force withstand to up 95% of the breaking load of the conductors according to the relevant specification. For substation applications, these requirements can be reduced. To reach high tension requirements, conductor entry clamp profiles are designed for minimum conductor stress. Mechanical tension forces in compression dead end clamp jumper loops are lower.
- The design of the conductor entry profile reduces risk of damage due to wind induced movement and vibrations.
- High currents caused by short circuit events are transmitted to the arcing devices through the string hardware. For a more detailed explanation, please refer to **Part 3** of the catalogue.
- Clamps have design profiles that reduce electrical stress and partial discharges to control corona extinction to above defined values.

Conductor bundle configurations combined with high nominal voltages at tension towers, may require fitment of **corona rings**.

## Material

- All materials used are fully compatible with the conductor application. For example, wedge clamps attached to aluminium based conductors are manufactured from high strength corrosion resistant aluminium alloys.
- Unless otherwise specified, all ferrous components are hot dipped galvanized acc. to *EN 61284* or *ISO EN 1461*; Overhead lines-requirements and tests for fittings. Where stainless steel fasteners are used, *ISO EN 3506*; Mechanical properties of corrosion resistant stainless steel fasteners - Part 1: Bolts, screws and studs are specified.
- **For special cases where big dynamic loads may occur at low temperatures, fittings made of low-temperature (cryogenic) steels are available.**
- **For lines constructed in higher corrosive atmospheres and environments, the minimum zinc thickness of fittings can be increased from 85 µ to 110 µ or 130 µ Microns.**
- All fitting assemblies supplied have **identification marking** according to *EN 61284*; this includes manufactures mark and date code, specified minimum mechanical failure load, and 1 second short circuit current withstand rating.

- Eye-clevis connections are designed acc. to IEC 61471 and DIN 48074 - Eyes and clevises; connecting dimensions, Bolts acc. to DIN 48073 - Connecting bolts for overhead power lines. Bolt security split pins are manufactured in stainless steel. Copper tinned types can also be supplied.

### Wedge tension clamps

These clamps can be used for overhead lines and substations.

The clamping effect of the wedge tension clamp is created by the wedge action converting tension load into compressive clamping loads. As tension loads increase, longitudinal wedge movement inside the housing increases clamping forces and strength.

Special grease lubrication of the wedges reduces friction increasing mechanical grip.

Clamp selection also depends on the conductor configuration. For ACSR applications, the designs of the conductor grooves are optimised to clamp the aluminium outer strands into the steel core providing good mechanical grip and strength. If wedge tension clamps are used, the jumper loops are usually connected by 2 or 3 parallel groove clamps.

In principle, two types are available:

**Wedge tension clamps**, are made of two forged bodies connected by a hinge with corresponding wedges. These can be with or without jumper connection. The jumper connection is forged with one of the two wedges. If, however, conductor diameters are bigger, it can also be connected by means of screws separately. Stainless Steel connecting screws are supplied as standard A2 quality. Hot dip galvanized screws can also be specified on request.

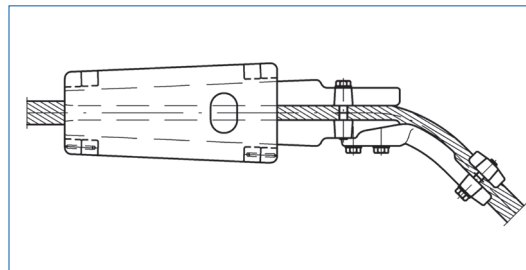

Wedge tension clamp with jumper connection

**Double wedge tension clamps** have two bodies made from a high-strength aluminium profile, with wedge designed as previously described. Hot dipped galvanized screws are standard, Stainless steel A2 quality screws can also be supplied. This type of clamp is suitable for smaller conductors only.

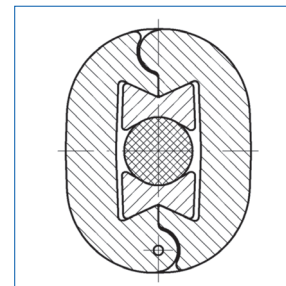

Cross section of a wedge tension clamp

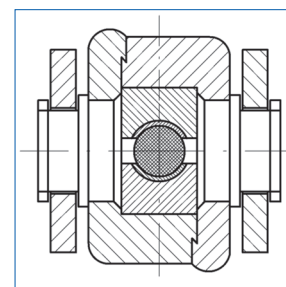

Cross section of a double wedge tension clamp

### Cone type tension clamps

These clamps work in the same way as wedge tension clamps, but the wedges are cone shaped. Cones are available with or without jumper connections. Depending upon the construction of the conductors or OPGW it can be necessary to use reinforcing rods. Cone diameters will be calculated acc. to the conductor dimensions.

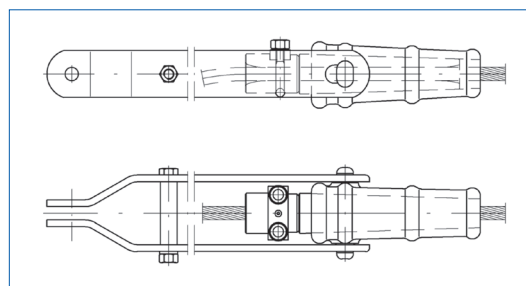

Cone type tension clamp

76

Wedge tension clamp for installation on site

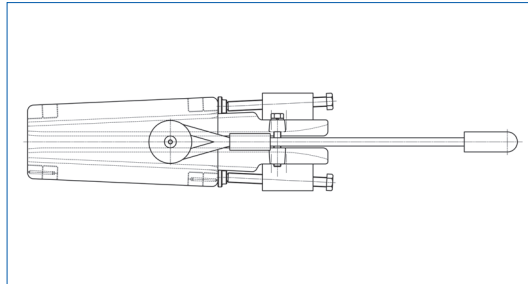

**Wedge tension clamp for installation on site**  
These wedge clamps are used to fix the conductor temporary while the original clamp will be fixed.

The installation clamps are equipped with flexible steel straps and a demounting device and make it possible to unload the endings of the conductor while fixing the original Compression dead end clamps.

Typical force-way chart for a compression dead end clamp

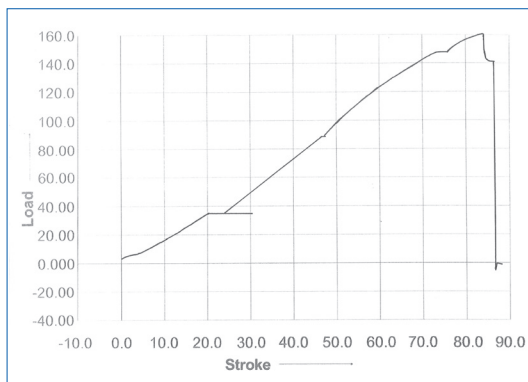

**Compression dead end clamps and compression joints**

These clamps can be used for overhead lines and substations, and can achieve the highest breaking loads using compression connection techniques.

For ACSR conductors, the internal core is compressed separately before the electrical connection sleeve. The clamps and joints are made using hydraulic compression utilising regular hexagonal dies, specified, identified and sized for each conductor joint.

Compression positions are marked on each joint.

**Compression devices are available upon request.**

Marking of compression points

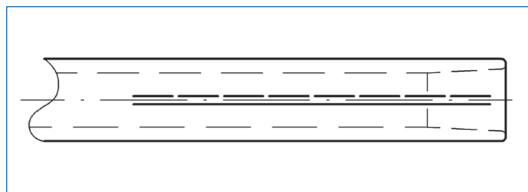

Taper of compression dead end clamps - standard design

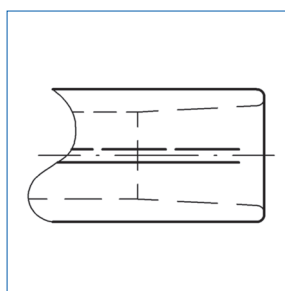

cable and connecting interfaces and prevent water ingress in exposed positions. Full jointing and assembly instructions are provided, that includes greasing application instructions.

Compression dead end clamps and joint tubes have internal conically tapers at the conductor entry as standard avoiding stress points by providing gradual compression load application. **External tube end tapers** can also be supplied.

The compression lug for the jumper shown is angled at 30° which determines jumper cable direction. For other applications, vertical

jumper directions are required e.g. substations. This is accommodated by two 15° angles, one on the dead end connecting flag, the other on the jumper lug.

By connecting the lug at opposite faces, vertical or 30° jumper exit angles are made. Other jumper exit angles are available upon request.

Possible connection variants of the jumper

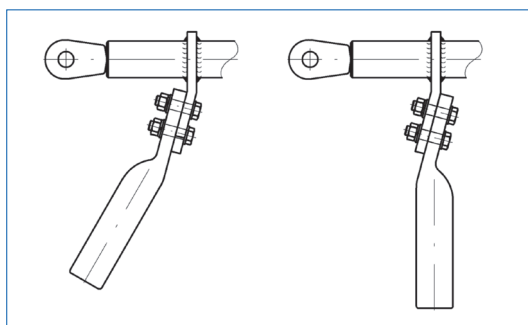

Hot dipped galvanised connecting screw sets are included within the jointing kit, stainless steel screws can also be supplied.

# 5

## TENSION CLAMPS AND JOINTS

Jumper loop tensions are accommodated by continuous weld fabrications, with additional load withstand and stabilisation possible with supporting straps.

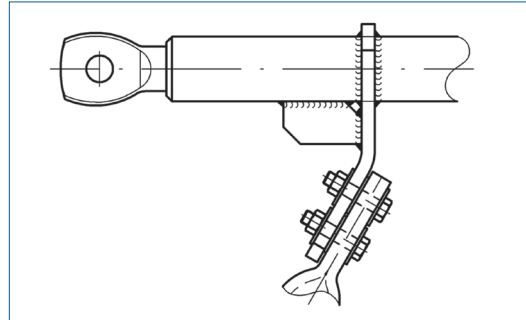

Compression dead end clamp with an increased retaining force for the loop

### Compression fittings for high-temperature carrying conductors

As power requirements increase, **high-temperature carrying conductors** with a capacity of up to 235°C will be more common.

However, the clamps used for these conductors must not be affected by high temperatures and maintain strength and mechanical performance.



Ageing test with compression dead end clamps for high-temperature carrying conductors in the laboratory

It is therefore necessary to increase the mass and surface area of clamp and joint designs to reduce thermal stresses.

Long-term testing at MOSDORFER testing laboratories demonstrates the effectiveness of these developments. These tests also prove suitability of different types of high temperature conductors e.g. where the steel core has a gap arranged loosely inside the conductor (e.g. GAP GZTACSR conductor).

For special projects, where electrical noise reduction is required due to cable corona discharge risks, larger diameter hollow conductors can be used that have the same electrical current carrying capacity and cross section as conventional conductors.

Fittings for hollow conductors can also be supplied.



Compression joint for the connection of a hollow conductor with an Aluminium-Steel conductor

78



Example for a  
heliformed  
dead end

## Helical wire fittings

Helical wire fittings are made of formed round wire rods, with the ends shaped depending on the material and diameter. The formed diameters of the wires are smaller than the diameter of cable to be applied. This creates uniform radial pre compression of the spiral without permanent distortion of the wires or sub-sets. This applies the initial low stress grip of the cable, which increases as a resultant of higher tension forces that convert to high frictional grip. Uniform radial loads and grip increase over a longer application and contact length that provide low relative and uniform radial stress.

Helical dead ends have multiple formed wires bonded together with a formed loop for strain thimble attachment. The inside of the helix of all helical tension fittings have a high friction textured finish to improve grip. The materials used are fully compatible with the cable being applied.

Identification and labelling of products are in accordance with *IEC 61284* (Rules of behaviour with respect to possible hazards when dealing with electric equipment and equipment employing similar techniques) will either be printed on individual rod sets or stated on a label connected to the set.

The lay direction of the helical rods is normally same as that of the outermost layer of the conductor, typically right hand lay.

The material used is the same as that of the conductor.

## Wedge tension clamp without jumper guide

for aluminium based conductors

**material: aluminium, forged; steel, hot dip galvanized**

L.-Nr.	dimensions in mm				kN	kA 1s	kg
	cond.Ø	A	B	bolt			
566.01/24FA	9,1 - 10,5	210	20	19	55	15	1,50
566.01/34FA	10,6 - 11,7	210	20	19	55	15	1,42
566.11/34FA	10,6 - 11,7	210	20	19	70	18	1,76
566.01/44FA	11,8 - 14,0	210	20	19	55	15	1,48
566.13/34FA	14,1 - 15,8	270	20	19	100	20	3,80
566.04/04FA	15,9 - 17,3	320	20	19	110	32	4,30
566.04/14FA	17,4 - 19,2	320	20	19	110	32	4,91
566.15/14FA	19,0 - 21,1	360	20	19	180	40	6,00
566.15/24FA	21,2 - 23,4	360	20	19	180	40	6,04

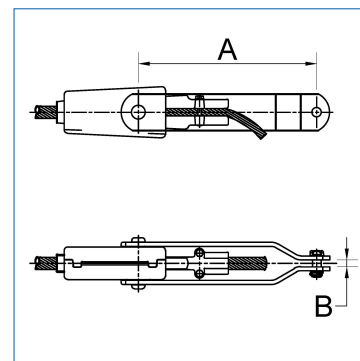

The stated values of breaking load refer to the straps, including connecting pieces. The retaining force of the clamp depends on the conductor configuration.

In the articles of L.-Nr. **566.01/** ... and **566.03/** ... the straps are riveted on the wedges.

**For steel and copper conductors, wedges made of steel can be inserted.**

Models with other screws and/or split pins are available upon request.

Other dimensions are available upon request.

## Wedge tension clamp with jumper guide

for aluminium based conductors

**material: aluminium, forged; steel, hot dip galvanized**

L.-Nr.	dimensions in mm				kN	kA 1s	kg
	cond.Ø	A	B	bolt			
566.03/24NA	12,6 - 14,0	270	20	19	100	20	2,93
566.03/34NA	14,1 - 15,8	270	20	19	100	20	2,95
566.04/04NA	15,9 - 17,3	320	29	19	110	32	4,40
566.04/14NA	17,4 - 19,2	320	20	19	110	32	4,34
566.15/14NA	19,0 - 21,1	360	20	19	180	40	6,60
566.15/24NA	21,2 - 23,4	360	20	19	180	40	6,40
566.15/34NA	23,5 - 24,8	360	20	19	180	40	6,40
566.16/14NA	23,5 - 25,6	435	20	19	200	40	10,69
566.16/24NA	25,7 - 27,9	435	20	19	200	40	10,74
566.16/34NA	28,0 - 30,1	435	20	19	200	40	10,50
566.16/44NA	30,2 - 32,4	435	20	19	200	40	10,60
566.16/54NA	32,5 - 33,4	435	20	19	200	40	10,35

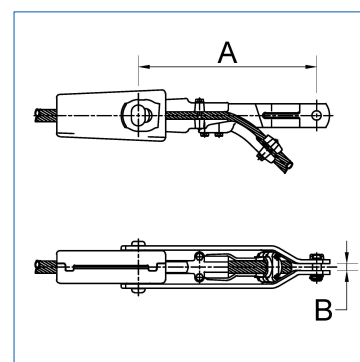



**material: aluminium, forged; steel, hot dip galvanized**

L.-Nr.	dimensions in mm				kN	kA 1s	kg
	cond.Ø	A	B	bolt			
566.17/25NA	32,9 - 36,0	525	20	22	300	50	19,20
566.17/35NA	36,1 - 39,2	525	20	22	300	50	19,17
566.17/45NA	39,3 - 42,4	525	20	22	300	50	18,90

The stated values of breaking load refer to the straps, including connecting pieces. The retaining force of the clamp depends on the conductor configuration.

In the articles of L.-Nr. **566.03/** ... the straps are riveted on the wedges.

**For steel and copper conductors, wedges made of steel can be inserted.**

Models with other screws and/or split pins are available upon request.

Other dimensions are available upon request.

## Double wedge tension clamp without jumper guide for aluminium based conductors

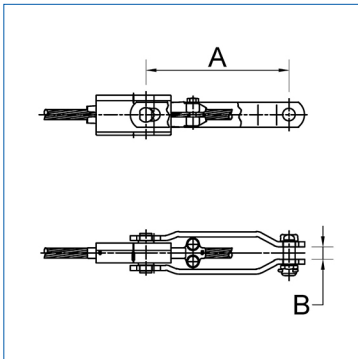

**material: aluminium, extruded; steel, hot dip galvanized**

L.-Nr.	dimensions in mm				kN	kA 1s	kg
	cond.Ø	A	B	bolt			
4440.50/4	7,5 - 10,0	210	20	19	60	13	1,12
4440.51/3	10,5 - 12,5	210	20	19	60	13	1,11
4440.52/1	13,6 - 16,1	310	14	13	60	16	2,25
4440.53/1	13,6 - 16,1	310	20	19	80	22	2,35

The stated values of breaking load refer to the straps, including connecting pieces. The retaining force of the clamp depends on the conductor configuration.

Double wedge tension clamps have a connecting bolt that is made of steel and ensures that abrasion is limited, when connected with the steel eyes.

Other dimensions are available upon request.





## Double wedge tension clamp with jumper guide

for aluminium based conductors

**material: aluminium, extruded; steel, hot dip galvanized**

L.-Nr.	dimensions in mm				kN	kA 1s	kg
	cond.Ø	A	B	bolt			
4440.52/4	13,6 - 16,1	310	14	13	60	18	2,40
4440.52/3	13,6 - 16,1	310	14	13	60	18	2,41
4440.53/3	13,6 - 16,1	310	20	19	80	22	2,50

The stated values of breaking load refer to the straps, including connecting pieces. The retaining force of the clamp depends on the conductor configuration.

Double wedge tension clamps have a connecting bolt that is made of steel and ensures that abrasion is limited, when connected with the steel eyes.

Other dimensions are available upon request.

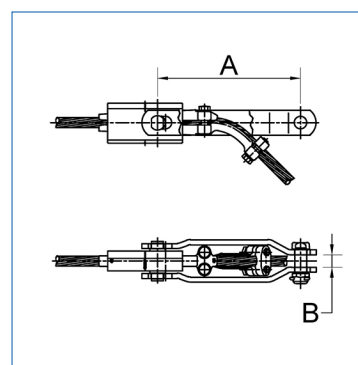

## Bolted type tension clamp

for aluminium based conductors

**material: aluminium, casted; steel, hot dip galvanized**

L.-Nr.	dimensions in mm		bolt	U-bolts	kN	kA 1s	kg
	cond.Ø	A					
4432.08	5,0 - 13,5	17	13	2 X M8	40	10	0,46
4432.08/1	7,0 - 15,0	20	16	2 X M8	50	25	0,54
4432.14/10	8,0 - 18,5	19	16	2 X M12	50	25	1,02
4432.14	9,0 - 16,0	23	16	3 X M10	60	25	0,98
4432.15/10	12,0 - 25,5	26	16	3 X M12	60	25	1,40
4432.15/11	12,0 - 29,0	30	16	4 X M14	70	25	3,90
4432.15/11/1	12,0 - 29,0	30	19	4 X M14	70	40	3,95
4432.15	16,0 - 20,0	24	16	4 X M12	85	25	1,90
4432.16/10/1	18,0 - 35,0	36	19	5 X M16	120	40	6,70
4432.16/10/2	18,0 - 35,0	36	22	5 X M16	120	40	6,20
4432.16/10	18,0 - 35,0	36	25	5 X M16	120	50	6,20

The stated values of breaking load refer to the clamp fork, including connecting pieces. The retaining force of the clamp depends on the conductor configuration.

**Clamps made of malleable iron for copper and steel conductors are available upon request.**

Other versions or dimensions are available upon request.

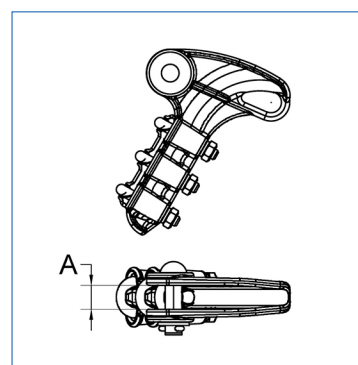

## Heliformed dead end with thimble and reinforcing rods for aluminium based conductors

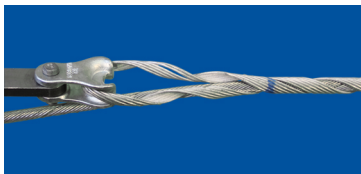
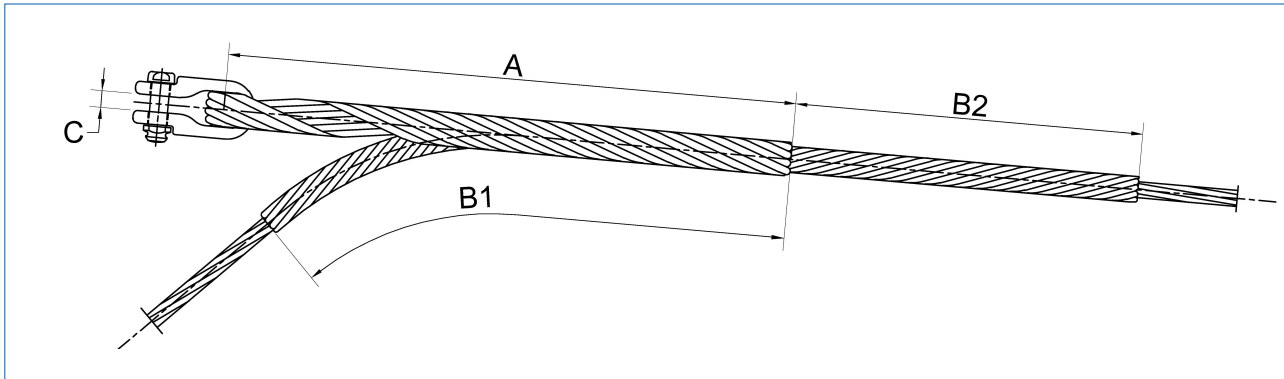

**material: aluminium, casted; steel, hot dip galvanized**

L.-Nr.	cond.Ø mm	dimensions in mm				kg
		A	B1	B2	C	
4480.06	7,25 - 8,53	870	1800	450	20	1,80
4480.03	8,54 - 10,45	900	1800	430	20	2,00
4480.00	10,47 - 11,50	1000	2000	475	20	2,40
4480.01	11,51 - 12,50	1200	2200	407	20	2,80
4480.02	12,51 - 13,26	1200	2500	573	20	3,50
4480.04	13,27 - 14,50	1500	2500	435	20	5,24
4480.05	14,51 - 15,50	1500	2900	533	20	5,03
4480.07	15,51 - 16,80	1600	3000	514	20	5,58
4480.08	16,81 - 17,80	1600	3000	550	20	5,90
4480.09	17,81 - 18,50	1700	3000	464	20	6,14
4480.10	18,51 - 19,70	1900	3000	550	20	8,36
4480.11	19,71 - 21,28	2000	3300	650	20	9,23
4480.12	21,29 - 22,00	2200	3300	513	20	10,18
4480.13	22,01 - 23,00	2200	3500	645	20	10,90
4480.14	23,01 - 23,60	2200	3500	675	20	10,90
4480.15	23,61 - 24,40	2400	3500	574	20	12,20
4480.16	24,41 - 25,30	2400	3500	608	20	12,40
4480.18	26,21 - 27,20	2400	3500	670	20	12,60

These articles are based on right-hand-layed conductors. Articles for left-hand-layed conductors are available upon request.

**Dead ends for ACS-strands in the outer layer are available upon request.**

Dead Ends for ADSS-conductors are available upon request.

Other dimensions are available upon request.

## Compression dead end clamps and compression joints

Compression fittings can be supplied in many variants:

e.g.

- clamps with bore holes for the filling with grease
- with twisted connection devices for quadruple bundles
- with a welded cable lug
- with an elongated cable lug as abrasion protection for vertical two bundles
- for Aluminium-Steel conductors with only one center wire clamps and joints without steel sleeve can be supplied

Compression dead end clamps and compression joints will be adapted to suit the conductor being used very accurately. For this reason, we have only included the DIN conductors as well as conductors using code names which are most commonly used.

Compression material for conductors with other material qualities or material types of aluminium can be supplied upon request.

Clamps with other connection devices and **oval eyes** can also be supplied upon request.

Compression fittings for ACSR with a big steel core will be delivered with a filler sleeve.

MOSDORFER offers compression fittings with internal tube end tapers as well as external tube end tapers, **the following pages explain the most common types.**

Other types upon request. Non tension fittings are also available. Materials for copper upon request.

### Compression dead end clamp with eye for ACSR

according to DIN Standard

**material: aluminium, extruded; steel, hot dip galvanized**

L.-Nr.	cond. cross section sq mm	cond.Ø mm	dimensions in mm						kg
					A	B	C	D	
4462.53	120/ 20	15,50	25	13	260	175	19	20	0,90
4462.62/1	240/ 40	21,80	34	15	375	220	19	20	1,72
4462.64/S	257/ 60	23,10	38	19	338	245	19	20	1,93
4462.66	300/ 50	24,40	38	17	330	245	19	20	2,20
4462.67	340/ 110	27,70	46	28	470	290	19	20	4,30
4462.74	680/ 85	36,00	58	23	510	320	19	20	6,00

Other dimensions and types are available upon request.

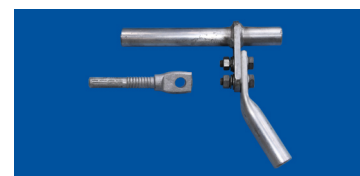
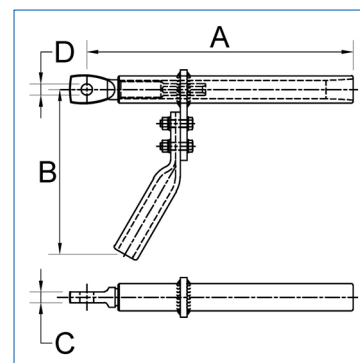

## Compression dead end clamp with eye for ACSR according to international standards

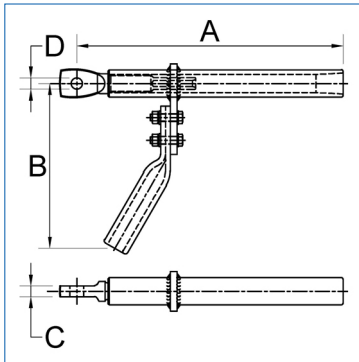

**material: aluminium, extruded; steel, hot dip galvanized**

L.-Nr.	cond. cross section sq code	cond.Ø mm	dimensions in mm				kg		
					A	B		C	D
4462.45	DOG	14,15	25	13	260	200	19	20	1,35
4462.41/1	WOLF	18,13	30	15	325	230	19	20	1,70
4462.78/2	CARDINAL	30,42	50	21	470	290	19	20	3,77
4462.0012	FINCH	32,85	52	21	495	315	19	20	4,20
4462.0015	GRACKLE	33,97	52	23	495	315	19	20	4,30
4462.82	PHEASANT	35,10	50	24	470	320	19	20	4,91
4462.133	MARTIN	36,17	58	23	510	320	19	24	6,00
4462.128	BLUEBIRD	44,76	70	23	590	370	19	24	10,50

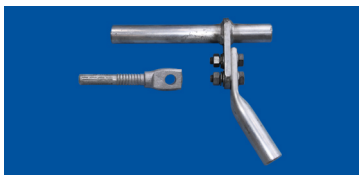

Other dimensions and types are available upon request.

## Compression dead end clamp with clevis for ACSR according to DIN Standard

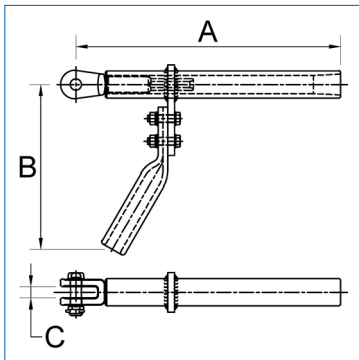

**material: aluminium, extruded; steel, hot dip galvanized**

L.-Nr.	cond. cross section sq mm	cond.Ø mm	dimensions in mm			bolt	kg		
			A	B	C				
4463.50/2	70/12	11,70	18	9	265	150	20	19	1,30
4463.49/2	50/30	11,70	28	15	275	190	20	19	1,60
4463.53	120/ 20	15,50	25	13	272	175	20	19	1,60
4463.98	95/55	16,00	30	19	290	200	20	19	1,65
4463.56	150/ 25	17,10	28	13	290	185	20	19	1,70
4463.130/1	105/75	17,50	34	21	330	200	20	19	2,00
4463.59	185/ 30	19,00	30	15	330	219	20	19	1,70
4463.63	230/30	21,00	34	15	330	215	20	19	1,92
4463.62	240/ 40	21,80	34	15	370	220	20	19	1,98
4463.48	265/35	22,40	38	15	330	245	20	19	2,40
4463.64/1	257/ 60	23,10	38	21	345	245	20	19	2,90
4463.65	300/ 50	24,50	38	17	330	346	20	19	2,40
4463.67	340/ 110	27,70	46	28	480	330	20	19	4,50
4463.110	450/40	28,70	46	15	440	290	20	22	4,20
4463.86/10/2	435/55	28,80	46	19	425	290	20	19	3,70
4463.78/10	490/65	30,60	50	21	470	290	20	19	4,10
4463.73/2	560/50	32,20	52	17	450	305	20	19	4,17
4463.72	550/70	32,40	52	21	470	305	20	19	7,20
4463.74/3	680/ 85	36,00	58	23	510	315	20	22	6,20
4463.103	1045/45	43,00	76	17	525	355	20	19	8,90
4463.103/3	1045/45	43,00	76	17	525	355	24	22	8,90



Other dimensions and types are available upon request.

## Compression dead end clamp with clevis for ACSR

according to international standards

**material: aluminium, extruded; steel, hot dip galvanized**

L.-Nr.	cond. cross section sq code	cond.Ø mm	dimensions in mm					bolt	kg
					A	B	C		
4463.0039	PETREL	11,70	28	15	275	190	20	19	1,60
4463.0009	LARK	15,50	25	13	272	175	20	19	2,00
4463.58/1	DORKING	16,00	30	19	325	200	20	19	1,70
4463.84	PARTRIDGE	16,28	28	13	290	185	20	19	1,70
4463.88/2	WOLF	18,13	30	15	330	235	20	19	1,73
4463.0079	ORIOLE	18,82	30	15	350	200	20	19	1,60
4463.87/1	LYNX	19,56	30	17	330	217	20	19	1,86
4463.0107	PELICAN	20,70	34	9	320	200	20	19	1,70
4463.85/1	PANTHER	21,00	34	17	385	220	20	19	2,10
4463.83	HAWK	21,80	34	15	370	220	20	19	2,22
4463.95	DOVE	23,55	38	17	365	245	20	19	2,41
4463.132	PEACOCK	24,19	38	15	330	245	20	19	2,40
4463.0035	SQUAB	24,56	46	17	370	250	20	19	3,30
4463.0085	SCOTER	25,90	42	21	400	250	20	19	3,30
4463.0031	TERN	26,90	42	15	355	250	20	19	3,00
4463.97	CONDOR	27,72	46	17	420	290	20	19	3,20
4463.108	DRAKE	28,11	46	21	435	290	20	19	3,98
4463.86/6	ZEBRA	28,62	46	19	425	290	20	19	4,20
4463.94/1	CARDINAL	30,42	50	21	467	290	20	19	4,10
4463.99/2	CURLEW	31,68	52	21	460	315	20	19	5,00
4463.109	BLUEJAY	31,96	52	15	450	315	20	19	4,47
4463.102	FINCH	32,85	52	21	495	315	20	19	4,67
4463.0098	GRACKLE	33,97	52	23	495	315	20	19	4,60
4463.101	PHEASANT	35,10	56	24	470	320	20	19	4,90
4463.75	BOBOLINK	36,23	58	17	460	315	20	22	5,48

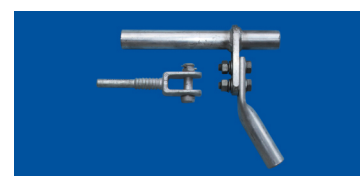
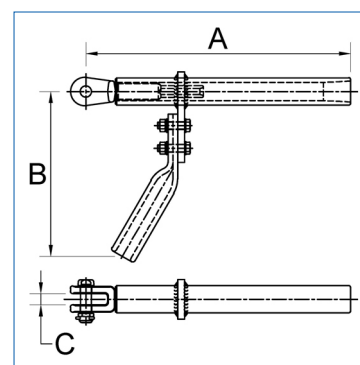

Other dimensions and types are available upon request.

## Compression dead end clamp with eye for AAAC according to DIN Standard

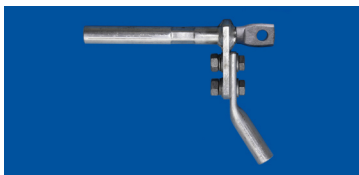
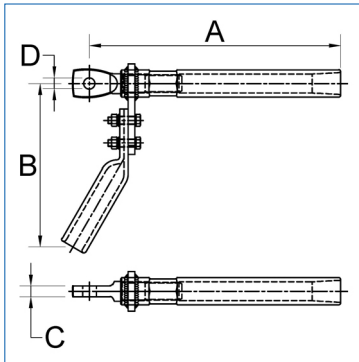

**material: aluminium, extruded; steel, hot dip galvanized**

L.-Nr.	cond. cross section sq mm	cond.Ø mm		dimensions in mm				kg
				A	B	C	D	
4455.0059	366	24,80	42	375	250	16	18	2,90

Other dimensions and types are available upon request.

## Compression dead end clamp with eye for AAAC according to international standards

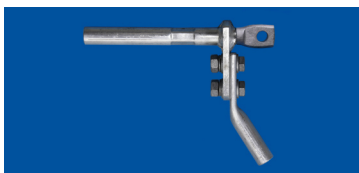
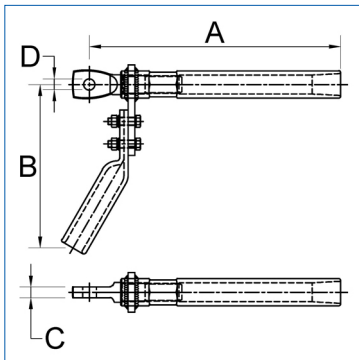

**material: aluminium, extruded; steel, hot dip galvanized**

L.-Nr.	cond. cross section sq code	cond.Ø mm		dimensions in mm				kg
				A	B	C	D	
4455.135	SULFUR	33,80	52	580	350	19	20	4,80
4455.0111	ASTER 1144	44,00	76	820	400	24	27	10,90

Other dimensions and types are available upon request.

## Compression dead end clamp with clevis for AAAC

according to DIN Standard

**material: aluminium, extruded; steel, hot dip galvanized**

L.-Nr.	cond. cross section sq mm	cond.Ø mm		dimensions in mm			bolt	kg
				A	B	C		
4455.109/2	95	12,50	22	235	160	20	19	1,25
4455.92	150	15,75	28	290	180	20	19	1,60
4455.78	175	18,34	30	330	230	20	19	1,80
4455.118	228	19,60	32	330	210	20	19	1,83
4455.94	240	20,25	34	370	245	20	19	1,90
4455.102	298	22,40	38	360	240	20	19	2,62
4455.0099	300	22,50	38	360	245	20	19	2,40
4455.114/3	366	24,85	42	375	250	20	19	2,90
4455.0039	400	26,00	42	380	250	20	19	3,40
4455.113/2	625	32,60	52	475	335	20	19	4,30

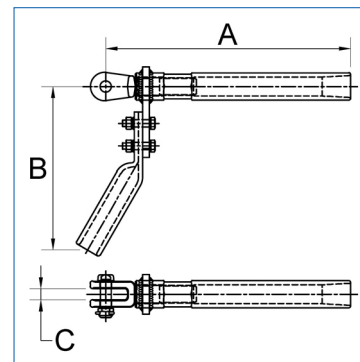

Other dimensions and types are available upon request.

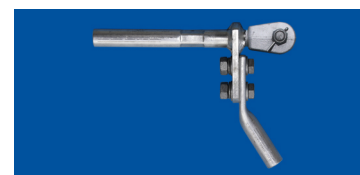

## Compression dead end clamp with clevis for AAAC

according to international standards

**material: aluminium, extruded; steel, hot dip galvanized**

L.-Nr.	cond. cross section sq code	cond.Ø mm		dimensions in mm			bolt	kg
				A	B	C		
4455.0109	ALLIANCE	14,30	25	280	180	20	19	1,40
4455.63	ASH	17,40	28	290	180	20	19	1,80
4455.95	CAIRO	19,89	34	370	245	20	19	2,00
4455.0069	SYCAMORE	22,60	38	380	245	20	19	2,40
4455.132	FLINT	25,13	42	375	250	20	19	3,20
4455.93	GREELEY	28,14	46	500	320	20	19	3,90
4455.100/5	YEW	28,42	46	425	290	20	19	3,12
4455.70/1	ALMELEC	31,05	50	480	290	20	19	4,15
4455.0029	RUBUS	31,50	52	570	315	20	19	4,70
4455.130	ARAUCARIA	37,26	64	628	360	20	22	8,10

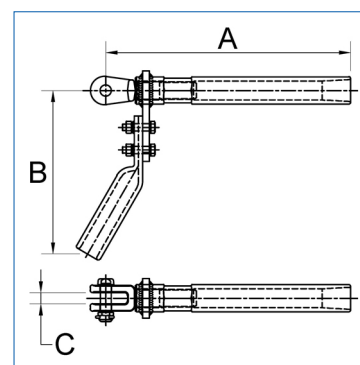

Other dimensions and types are available upon request.

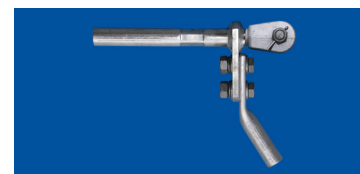

## Compression dead end clamp with eye

for steel and ACS-conductor

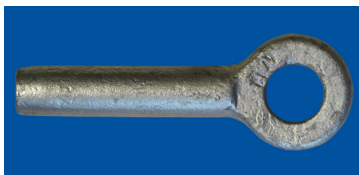
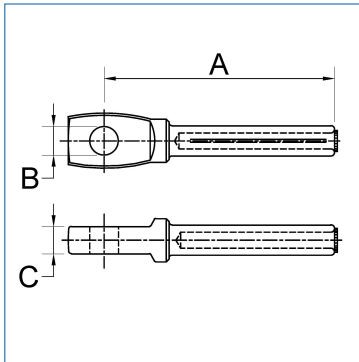

### material: steel, hot dip galvanized

L.-Nr.	cond. cross section sq mm/ code	cond.Ø mm	dimensions in mm			kg	
			A	B	C		
4459.10	ST 50	9,00	17	155	20	19	0,46
4458.11/1	AW 7 NO. 8 AWG	9,78	19	155	20	18	0,45

Other dimensions and types are available upon request.

## Compression dead end clamp with clevis

for steel and ACS-conductor

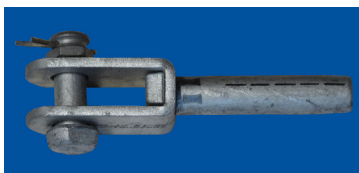
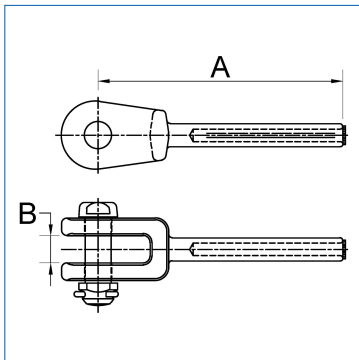

### material: steel, hot dip galvanized

L.-Nr.	cond. cross section sq mm/ code	cond.Ø mm	dimensions in mm		bolt	kg	
			A	B			
4458.18/2	AW 7 NO. 9 AWG	8,71	17	180	20	19	0,70
4458.23	AW 95	12,50	23	200	20	19	0,00
4458.29	AW 19 NO. 9 AWG	14,55	30	270	20	19	1,40
4458.30	ST IV 150	15,80	33	270	20	19	2,00

Other dimensions and types are available upon request.



## Compression joint for ACSR

according to DIN Standard

**material: aluminium, extruded; steel, hot dip galvanized**

L.-Nr.	cond. cross section sq mm	cond.Ø mm	dimensions in mm				kg
					A	B	
4854.11/D	44/32	11,20	25	15	380	150	0,46
4854.04	70/12	11,70	18	9	330	100	0,18
4854.29/D	50/30	11,70	25	15	370	140	0,50
4854.05	95/15	13,60	22	9	310	80	0,20
4854.06	120/20	15,50	25	13	360	130	0,40
4854.05/1/D	95/55	16,00	30	19	420	170	0,75
4854.07/D	150/25	17,10	28	13	390	115	0,50
4854.08/2D	185/32	19,00	30	15	440	150	0,60
4854.08	185/30	19,00	30	15	440	120	0,63
4854.09	210/35	20,30	34	15	490	160	0,70
4854.64/D	230/30	21,00	34	15	470	140	0,82
4854.18/D	210/50	21,00	34	17	500	170	1,20
4854.10	240/40	21,90	34	15	530	160	0,71
4854.10/D	240/40	21,90	34	15	470	140	0,76
4854.68/D	265/34	22,40	38	15	520	150	0,94
4854.20	257/60	23,10	38	21	500	160	1,23
4854.12	300/50	24,50	38	17	455	130	0,90
4854.12/D	300/50	24,50	38	17	540	170	1,13
4854.70/D	340/30	25,00	38	15	525	140	1,02
4854.21	310/100	26,60	42	25	610	230	1,90
4854.16/D	385/35	26,70	42	15	510	140	2,46
4854.13/D	380/50	27,00	42	17	560	170	1,45
4854.22	340/110	27,66	46	28	750	290	2,50
4854.22/D	340/110	27,66	46	28	760	290	2,50
4854.72/D	435/55	28,80	46	19	670	170	1,90
4854.56/10	490/65	30,60	50	21	680	160	2,30
4854.15/D	560/50	32,20	52	17	680	170	2,46
4854.25/D	550/70	32,40	52	21	730	230	2,75
4854.99	635/117	35,60	58	28	820	290	4,40
4854.26	680/85	36,00	58	23	760	230	3,65
4854.0155	1055/45	43,00	76	17	720	130	5,80

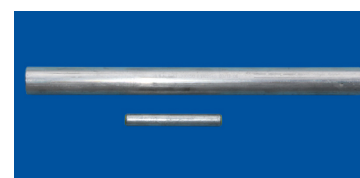
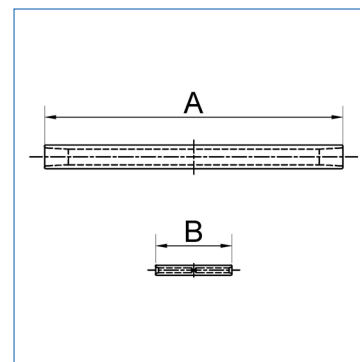

The L.-Nr. ..../D are equipped with external tube end tapers. Other dimensions and types are available upon request.

## Compression joint for ACSR according to international standards

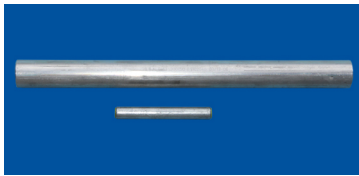
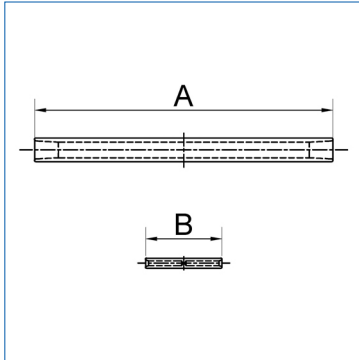

**material: aluminium, extruded; steel, hot dip galvanized**

L.-Nr.	cond. cross section sq code	cond.Ø mm	dimensions in mm				kg
					A	B	
4854.0019	PETREL	11,70	28	15	380	130	0,60
4854.87	MINORCA	12,20	25	15	360	120	0,40
4854.30	PERNICE	14,80	25	13	360	120	0,50
4854.0033	DOTTEREL	15,40	30	19	380	130	0,70
4854.58	DORKING	16,00	30	19	380	130	1,10
4854.48	PARTRIDGE	16,28	28	13	390	115	0,50
4854.57	COCHIN	16,85	34	21	520	170	1,40
4854.51	OSTRICH	17,28	28	13	390	115	0,50
4854.46/1	WOLF	18,13	30	15	455	130	0,66
4854.41	LINNET	18,30	30	15	440	120	0,70
4854.43/1	LYNX	19,56	30	17	455	130	0,66
4854.59	IBIS	19,88	34	15	450	120	0,70
4854.67	PANTHER	21,00	34	17	560	190	1,00
4854.62	FLICKER	21,48	34	15	530	160	0,90
4854.47	HAWK	21,80	34	15	530	160	0,90
4854.0156	HEN	22,40	38	19	580	190	1,30
4854.31	DOVE	23,55	38	17	525	160	0,98
4854.0042	PEACOCK	24,20	38	15	525	160	0,90
4854.28/10	GROSBEAK	25,15	42	17	495	130	1,10
4854.0002	BISON	27,00	42	17	530	160	1,30
4854.60	CONDOR	27,72	46	17	580	130	1,68
4854.23	DRAKE	28,11	46	21	620	160	1,90
4854.45/1	ZEBRA	28,62	46	19	600	130	1,90
4854.56	CARDINAL	30,42	50	21	680	160	3,10
4854.25/1	CURLEW	31,68	52	21	650	190	2,45
4854.83	BLUEJAY	31,98	52	15	640	130	2,40
4854.88	FINCH	32,85	52	21	710	190	2,27
4854.66	PHEASANT	35,10	56	24	670	160	2,86
4854.26/1	MARTIN	36,17	58	23	760	230	3,85
4854.42	BOBOLINK	36,23	58	17	650	130	2,75
4854.0085	FALCON	39,26	64	25	940	230	5,00
4854.0053	CHUKAR	40,70	64	21	940	230	4,80
4854.84	BLUEBIRD	44,76	70	23	820	230	6,00

Other dimensions and types are available upon request.

## Compression joint for AAAC

according to DIN Standard

**material: aluminium, extruded**

L.-Nr.	cond. cross section sq mm	cond.Ø mm		dimension in mm	kg
				A	
4853.03	50	9,00	16	155	0,06
4853.0058	75	11,25	18	165	0,10
4853.05	95	12,50	20	165	0,10
4853.10	150	15,80	28	320	0,40
4853.08	185	17,50	28	375	0,36
4853.41	240	20,30	34	450	0,70
4853.11	248	20,45	34	450	0,70
4853.0034	300	22,50	38	410	0,80
4853.22	366	24,85	42	450	0,95
4853.12	400	26,00	42	450	0,95
4853.13	500	29,10	46	520	1,27
4853.15/1	570	31,05	50	630	2,00
4853.110	600	31,90	52	373	2,10
4853.103	800	36,80	64	870	4,60

Other dimensions and types are available upon request.

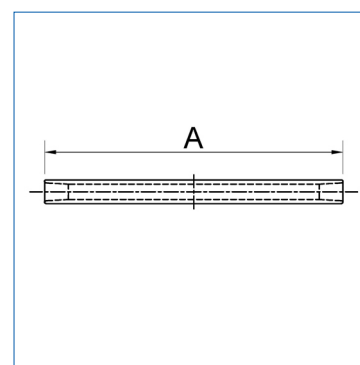

## Compression joint for AAAC

according to international standards

**material: aluminium, extruded**

L.-Nr.	cond. cross section sq code	cond.Ø mm		dimension in mm	kg
				A	
4853.0038	ALLIANCE	14,30	25	280	0,30
4853.109	ELM	18,80	30	375	0,40
4853.37	CAIRO	19,88	34	450	0,70
4853.0022	SYCAMORE	22,60	38	450	0,90
4853.0007	UPAS	24,71	42	450	0,95
4853.104	FLINT	25,13	42	450	1,00
4853.36	GREELEY	28,00	46	690	1,80
4853.100	YEW	28,42	46	520	1,27
4853.0006	RUBUS	31,50	52	373	0,70
Z4853.0047	ARAUCARIA	37,26	64	870	4,60

Other dimensions and types are available upon request.

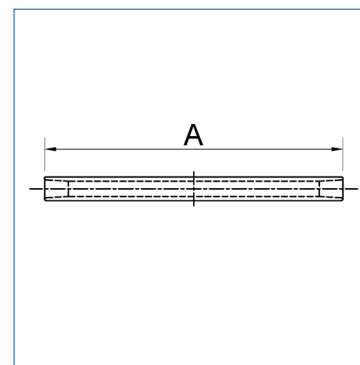

## Compression joint for steel and ACS-conductor

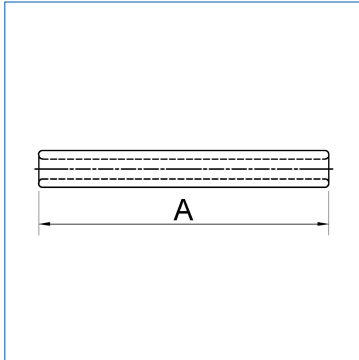

### material: steel, hot dip galvanized

L.-Nr.	cond. cross section sq mm/ code	cond.Ø mm	dimension in mm		kg
				A	
4858.0020	ST 7	7	15	160	0,15
4858.08	AW 38	7,80	15	160	0,16
4858.0007	ST 5/16"	7,92	15	160	0,15
4858.12	ST 50	9	17	190	0,30
4858.0002	ST 3/8"	9,15	19	225	0,40
4912.09	ST 9.52 MM	9,52	19	220	0,35
4912.01	AW 7 NO. 8 AWG	9,78	19	225	0,40
4858.13	ST 70	10,50	21	225	0,43
4858.22	ST 7/16"	11,11	21	225	0,45
4858.05/1	ST 79	11,50	23	260	0,60
4858.19/1	ST 11,80	11,80	23	260	0,60
4858.0029	ST 12	12	23	260	0,60
4912.05	AW 7 NO. 6 AWG	12,34	23	260	0,59
4858.14	ST 95	12,50	23	260	0,58
4858.21	ST 12,70	12,70	23	260	0,55
4912.0003	AW 7 NO. 5 AWG	13,87	23	360	1,30
4858.0018	AW 19 NO. 9 AWG	14,55	30	410	1,60
4858.25	ST 150	15,80	33	410	2,20

Other dimensions and types are available upon request.

## Repair sleeve

for aluminium based conductors

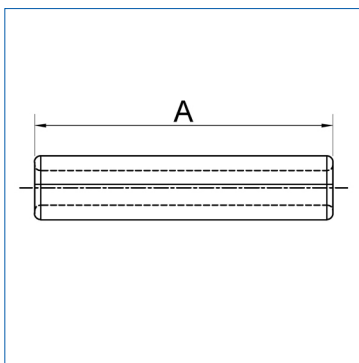

### material: aluminium

L.-Nr.	cond.Ø mm	dimension in mm		kg
			A	
4880.0004	11,7	18	150	0,04
4880.37/2	13,8 - 14,7	25	200	0,20
4880.17	14,8 - 15,7	25	200	0,15
4880.18	15,6 - 16,6	28	200	0,20
4880.22	16,7 - 17,6	28	200	0,20
4880.80/15	17,4 - 18,4	30	200	0,23
4880.80/17	18,5 - 19,6	30	200	0,22
4880.80/18	19,6 - 21,4	34	200	0,30
4880.27/1	21,5 - 22,8	38	220	0,38
4880.24	22,9 - 23,8	38	220	0,40
4880.19	23,9 - 25,2	42	220	0,50
4880.50	25,3 - 27,1	42	250	0,53
4880.28	26,3 - 28,1	46	250	0,69
4880.29	27,7 - 29,0	46	250	0,61
4880.20	28,6 - 30,5	48	250	0,68
4880.26	30,6 - 32,9	52	250	0,80
4880.42	33,8 - 35,1	56	280	1,06
4880.30	34,4 - 36,6	58	280	1,50

**material: aluminium**

L.-Nr.	cond.Ø mm		dimension in mm	kg
			A	
4880.31	36,2 - 38,6	64	280	1,50
4880.32	47,8 - 50,9	76	350	2,22

For damages of maximum 25% of the strands of the outer layer.

The repair sleeves are made up of two halves that can be slid over the damaged point of the conductor. In case of major damage, it will be recommended to use heliformed rods.

Other types are available upon request.

## Repair sleeve

for steel and ACS-conductor

**material: aluminium**

L.-Nr.	cond.Ø mm		dimension in mm	kg
			A	
4881.17	8,71	17	150	0,20
4881.0002	9,15	19	150	0,30
4881.0006	9,80	19	150	0,40
4881.19	10,50	19	150	0,25
4881.24	10,50	21	150	0,29
4881.0009	11,00	21	150	0,30
4881.23/2	11,50	23	150	0,40
4881.23/4	12,34	23	150	0,40

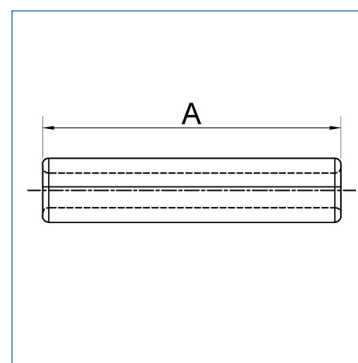

For damages of maximum 25% of the strands of the outer layer.

The repair sleeves are made up of two halves that can be slid over the damaged point of the conductor. In case of major damage, it will be recommended to use heliformed rods.

