

APPLICATION

Current transformers are used to separate measuring and protective equipment from high voltages and to transform measured currents to values adequate to the measuring and protection equipment.

STANDARDS

The current transformers are designed in accordance with IEC, VDE, ANSI, BS or other agreed standards.

DESCRIPTION OF MAIN PARTS

- The transformers are designed for one or two rated primary currents, without primary reconnection or with 1:2:4 primary reconnection. Reconnection is very simple by re-arrangement of links at HV terminals.
- Current transformers can also be with secondary taps, and with both primary reconnection and secondary taps.
- Transformer cores are wound, made either of cold-rolled grain-oriented magnetic steel or soft magnetic material (Mumetal) depending on the required accuracy.
- The secondary winding is uniformly wound around the core, and the primary winding passes through its centre. This enables usage of a computer programme for accurate computation of CT response in transient states in the network. Current transformers of accuracy classes TPS, TPX, TPY and TPZ are defined in the standard IEC 60044-6/92.
- The insulation between the windings and the grounded parts is made of insulating paper impregnated with transformer oil under high vacuum. Conductive screens inserted into the main insulation provide a capacitor bushing that improves the resistance of CTs to atmospheric impulse voltages.

- Transformers are filled with high-quality oil with added inhibitor, which improves its aging resistance. Degassing and dehydrating of oil are made in high vacuum up to a moisture content less than 10 microgram per gram, what ensures excellent dielectric properties. We guarantee that the transformer oil in our instrument transformers is free from any polychlorinated biphenyls and terphenyls (PCB and PCT).
- Primary terminals are made of electrolytic copper or aluminium. Copper terminals are corrosion protected by hot dip tinning or silver coating.
- Secondary terminals are inside the secondary terminal box, together with earthing terminal for secondary windings. They are made of M8 stainless steel screw.
- The transformer housing is made of welded steel plates. High quality anti-corrosive protection is achieved by hot dip galvanizing. The transformer head is made of casted aluminium.
- The insulator is made of high-quality porcelain, cylindrically shaped and brown-glazed (if requested, the glaze can be of some other colour). Creepage distance depends on ambient air pollution at the place of installation. Standard creepage distances are 20, 25 or 31 mm per kV of highest voltage of equipment, depending on client's request. Besides porcelain, the insulator, as the outside insulation, can be also made of composite material (GFK silicone).
- Heat dilatation of oil volume is compensated by metal bellows made of stainless steel.
- Seismic resistance of the transformer is higher than 0.3 g.

1. Bellows guard
2. Vent screw
3. Bellows position indicator
4. Expansion bellows
5. HV insulation
6. Secondary winding
7. Primary winding

8. Transformer head
9. Insulator
10. Housing
11. Secondary terminal box
12. Secondary terminals
13. Oil drain and filling plug

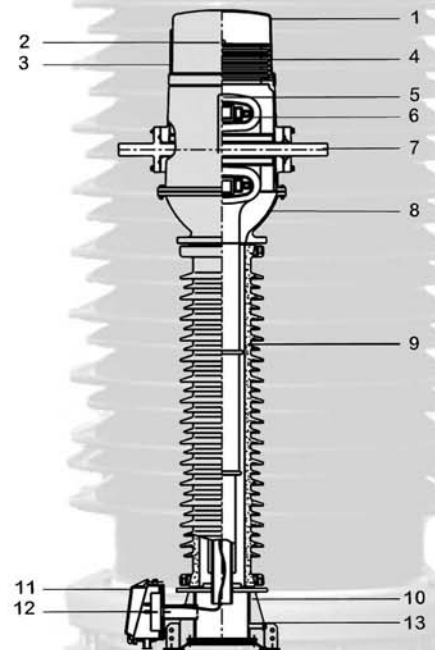

MAIN CHARACTERISTICS

- Rated primary currents are for:
 - transformers without primary reconnection up to 6000 A
 - transformers with primary reconnection 1:2 up to 2 x 2500 A
 - transformers with primary reconnection 1:2:4 up to 4 x 1000 A.
- Rated secondary current can be 1, 2 or 5 A.
- The number of cores, that are within the aluminium torus, rated burden of each core, measuring and protection accuracy classes, safety factor and accuracy limit factor as well as the continuous thermal current are in accordance with client's requests and agreed standards.
- Rated short-time thermal current is 100 x I_n or max. 50 kA; rated dynamic current: 250 x I_n or max. 125 kA (except if otherwise necessary).
- The standard transformer designs are intended for ambient temperatures -25 / +40°C.



Transformer head

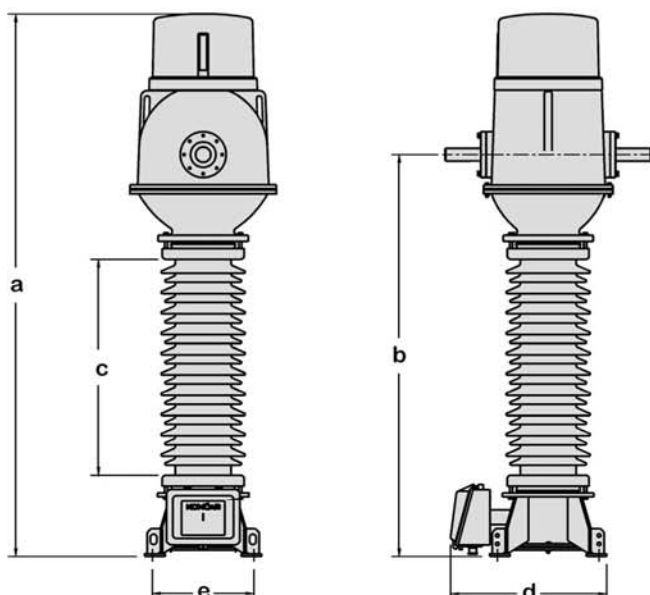

Secondary terminal box

Type	a (mm)	b (mm)	c (mm)	d (mm)	e (mm)	weight (kg)
AGU-38	1190	850	370	430	4xØ16/□280	100
AGU-72.5	2050	1485	770	615	4xØ18/□400	350
AGU-123	2530	1870	1150	615	4xØ18/□400	400
AGU-145	2710	2055	1340	615	4xØ18/□400	450
AGU-170	3175	2350	1455	780	4xØ26/□520	650
AGU-245	3925	3100	2200	780	4xØ26/□520	800
AGU-300	3925	3100	2200	780	4xØ26/□520	950
AGU-362	4500	3680	2820	780	4xØ26/□520	1100
AGU-420	5345	4435	3440	915	4xØ26/□650	1350
AGU-525	5880	4970	3975	915	4xØ26/□650	1500
AGU-765	6930	5910	4880	1000	4xØ26/□750	2100

Note: Data given in this prospect are for informative purposes only. With the view of constant improvement of quality of our product we reserve the right to changes.